



"Gulf Armor" WOOD GLAZED OR OPAQUE SINGLE DOOR w/ TRANSOM w/ or w/out SIDELITE(S) IN SWING/OUT SWING "IMPACT"

GENERAL NOTES

1. This product has been evaluated and is in compliance with the 6th Edition (2017) Florida Building Code (FBC) structural requirements excluding the "High Velocity Hurricane Zone" (HVHZ).
2. Product anchors shall be as listed and spaced as shown on details. Anchor embedment to base material shall be beyond wall dressing or stucco.
3. When used in areas requiring wind borne debris protection this product complies with FBC Sections 1609.1.2 & R301.2.1.2 and does not require an impact resistant covering. This product meets missile level "D" and includes Wind Zone 4 as defined in ASTM E1996 and FBC Sections 1609.1.2.2 & R301.2.1.2.1.
4. For 2x stud framing construction, anchoring of these units shall be the same as that shown for 2x buck masonry construction.
5. Site conditions that deviate from the details of this drawing require further engineering analysis by a licensed engineer or registered architect.

TABLE OF CONTENTS

SHEET#	DESCRIPTION
1	Typical Elevations, Design Pressures & General Notes
2	Door Panel Details
3	Sidelite Panel Details
4	Transom Details
5	Elevations
6	Horizontal & Vertical Cross Sections (2X Buck)
7	Horizontal & Vertical Cross Sections (1X Buck)
8	Horizontal & Vertical Cross Sections
9	Vertical Cross Sections (Thresholds)
10	Buck & Frame Anchoring (O/X)
11	Buck & Frame Anchoring (O/OX)
12	Buck & Frame Anchoring (O/OXO)
13	Hardware Details
14	Bill of Materials & Components

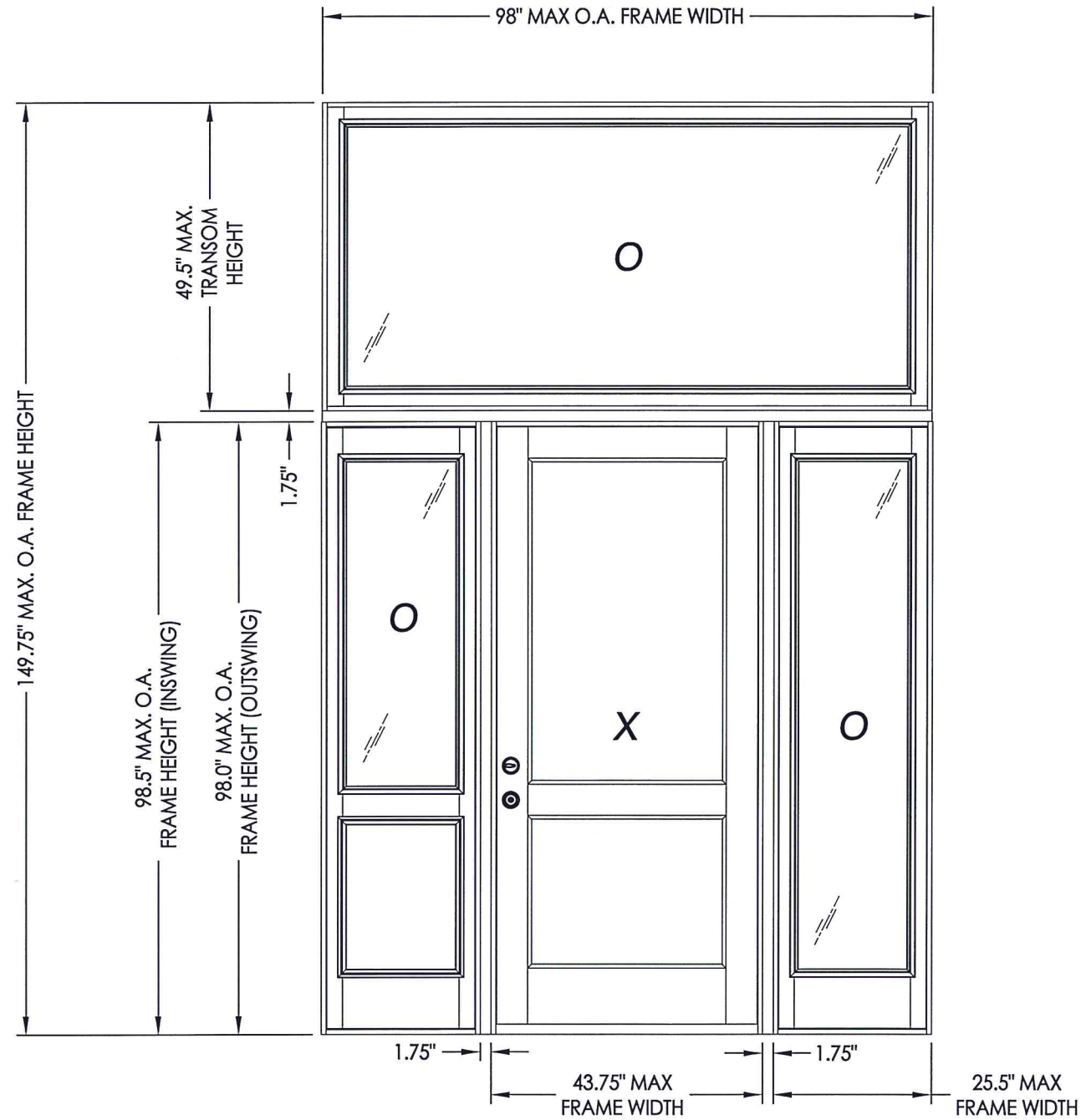

CONFIGURATION	DESIGN PRESSURE (PSF) INSWING		DESIGN PRESSURE (PSF) OUTSWING	
	POSITIVE	NEGATIVE	POSITIVE	NEGATIVE
$\begin{matrix} \text{O} & \text{O} & \text{O} & \text{O} \\ \text{X} & \text{OX} & \text{XO} & \text{OXO} \end{matrix}$	+50.0	-50.0	+50.0	-50.0

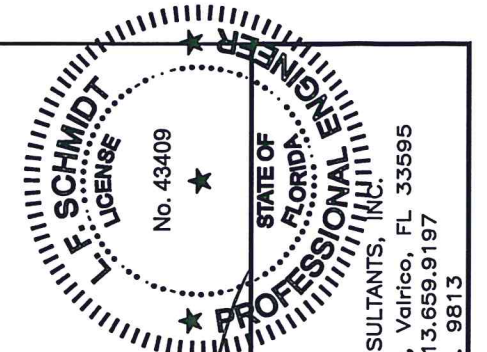

October 12, 2017
 Documents Prepared By:
 Lyndon F. Schmidt
 P.E. No. 43409
 R.W. BUILDING CONSULTANTS, INC.
 P.O. Box 230, Valrico, FL 33595
 Phone No.: 813.659.9197
 FBPE C.A. No. 9813

PRODUCT:	SOUTHEASTERN SASH & DOOR WOOD DOOR
PART OR ASSEMBLY:	TYPICAL ELEVATION, DESIGN PRESSURES & GENERAL NOTES
DATE	5/10/17
NO.	1
BY	LFS
REVISIONS	10/12/17 UPDATE TO 6TH ED. (2017) FBC

R:\Clients\Southeastern Sash & Door\A - Florida Product Approvals\FL-22347C - Drawings\FL-22347 (2017)\FL-22347.1-3.dwg, 2.3

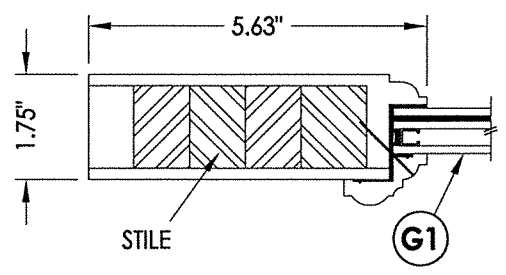

1 HORIZONTAL CROSS SECTION
2

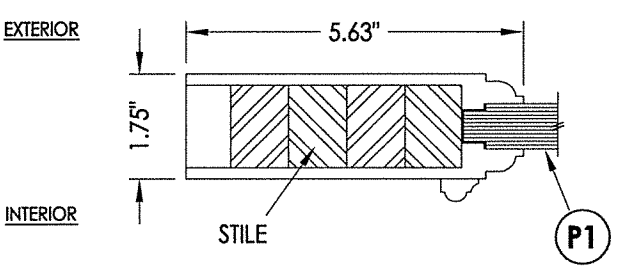

2 HORIZONTAL CROSS SECTION
2

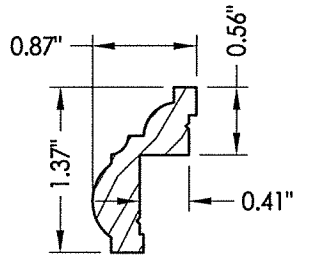

GLAZING BEAD

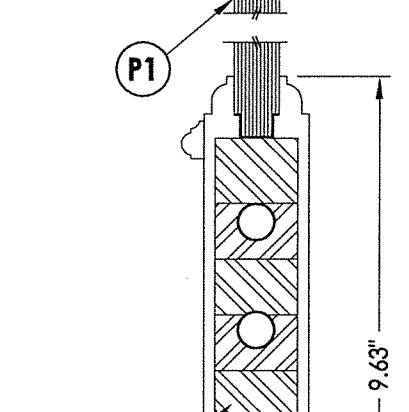
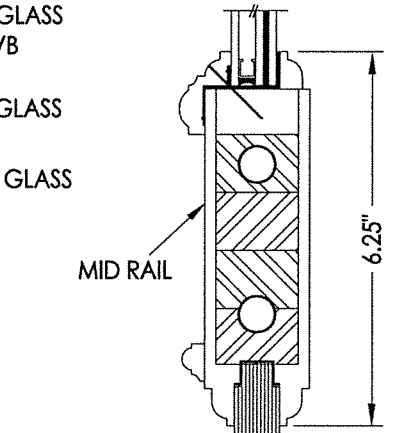
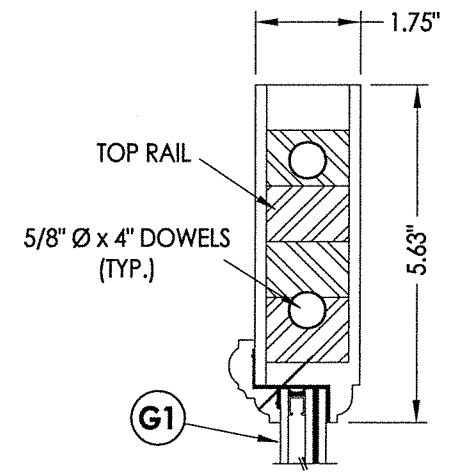

3 VERTICAL CROSS SECTION
2

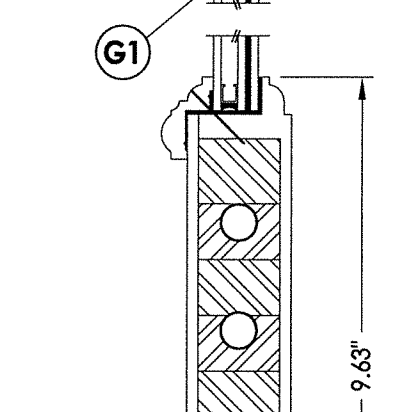
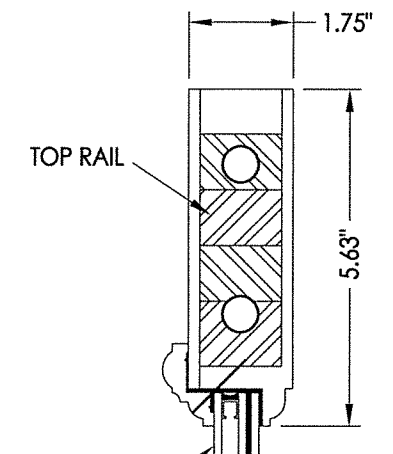

4 VERTICAL CROSS SECTION
2

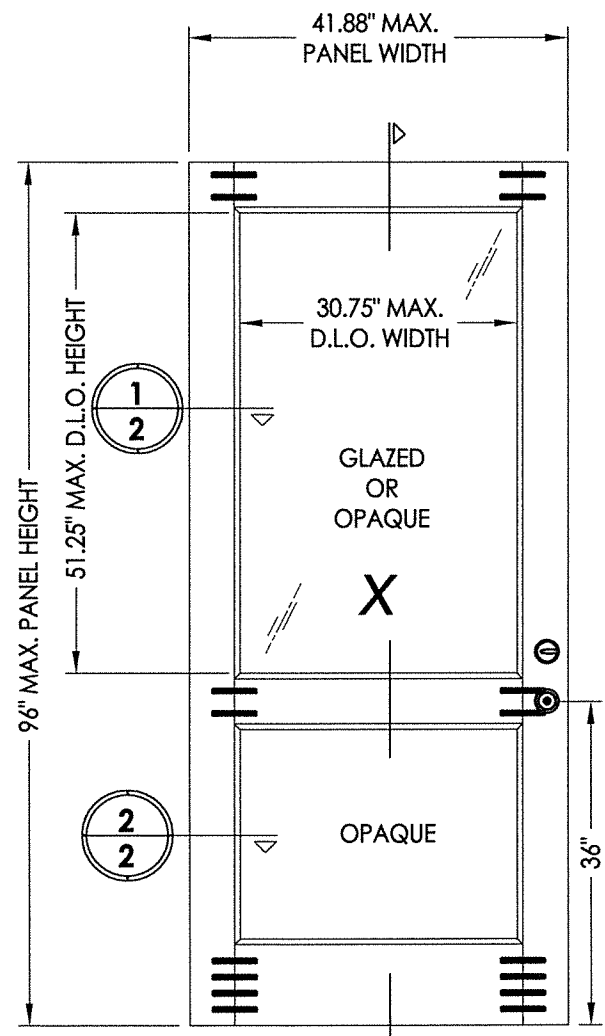

3/4 PANEL/LITE

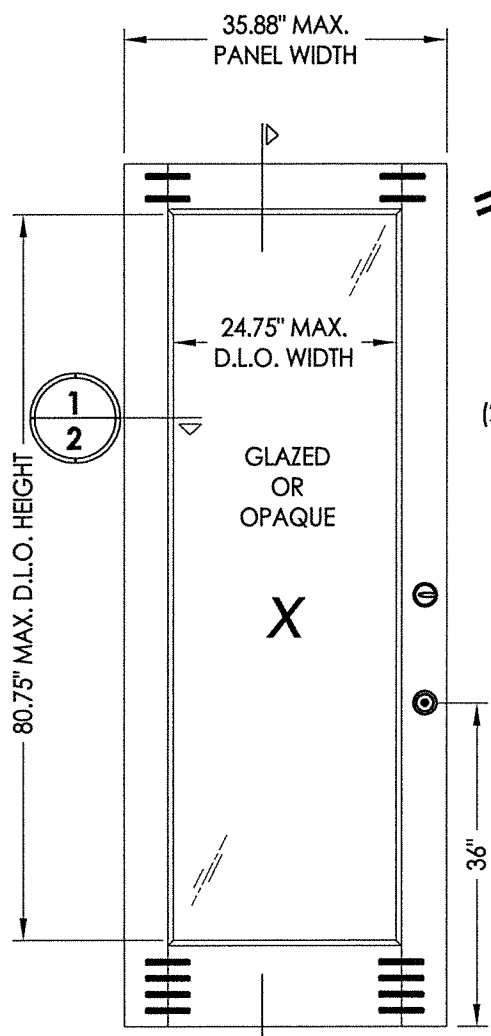

FULL PANEL/LITE

40 WOOD DOOR PANEL
Glazed or Opaque

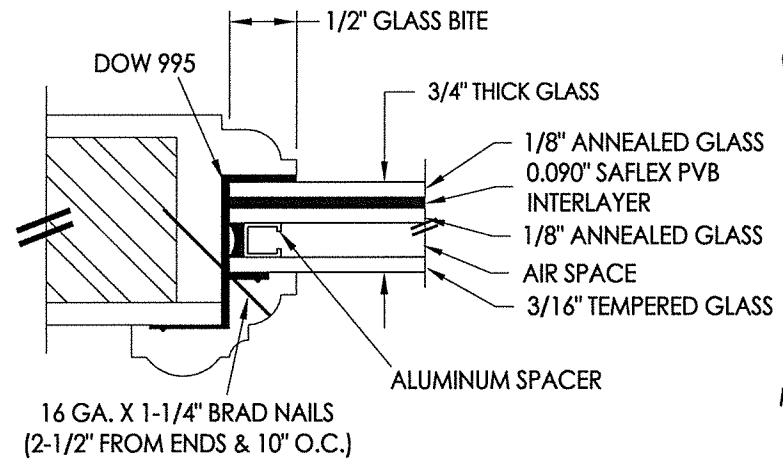

G1 GLAZING DETAIL

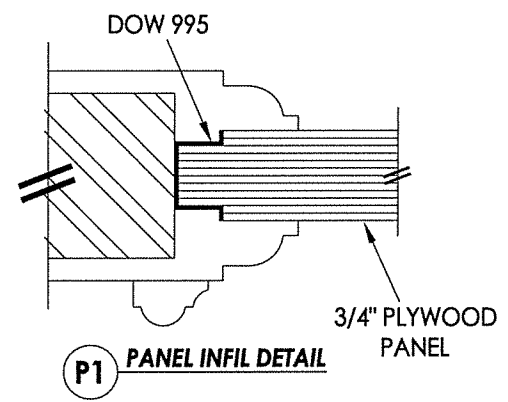

P1 PANEL INFIL DETAIL

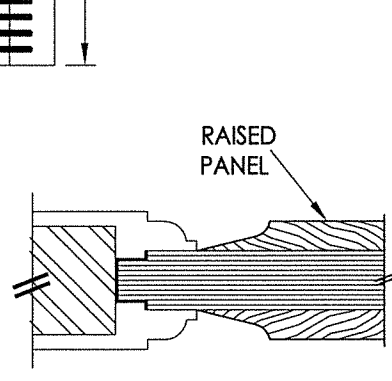

RAISED PANEL OPTION

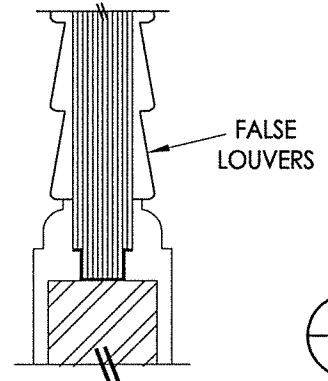

FALSE LOUVER OPTION

WOOD DOOR COMPONENTS:
VENEER/EDGES: CYPRESS (G = 0.42)
ENGINEERED STAVE CORE: SIPO (UTILE) (G = 0.53)

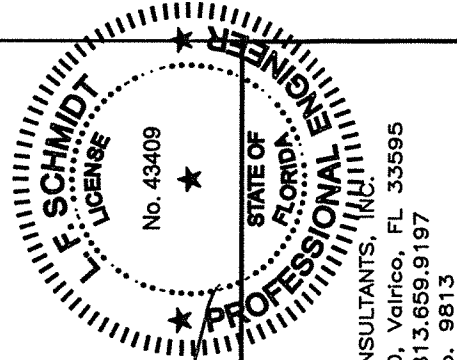

October 12, 2017
Documents Prepared By:
Lyndon F. Schmidt
P.E. No. 43409
RW BUILDING CONSULTANTS, INC.
P.O. Box 230, Valrico, FL 33595
Phone No.: 813.659.9197
FBPE C.A. No. 9813

PRODUCT: SOUTHEASTERN SASH & DOOR WOOD DOOR
PART OR ASSEMBLY: DOOR PANEL DETAILS

NO.	DATE	REVISIONS
1	10/12/17	UPDATE TO 6TH ED. (2017) FBC
		LFS
		BY

DATE: 5/10/17
SCALE: N.T.S.
DWG. BY: JK
CHK. BY: LFS
DRAWING NO.: FL-22347.3
SHEET 2 OF 14

© 2017 R.W. BUILDING CONSULTANTS INC.

R:\Clients\Southeastern Sash & Door\A - Florida Product Approvals\FL-22347C - Drawings\FL 22347 (2017)\FL-22347.1-3.dwg, 3.3

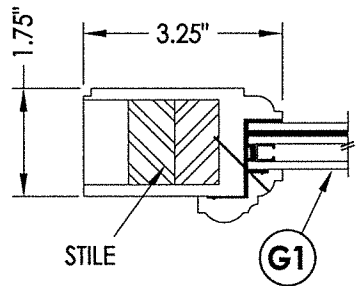

1
3 HORIZONTAL CROSS SECTION

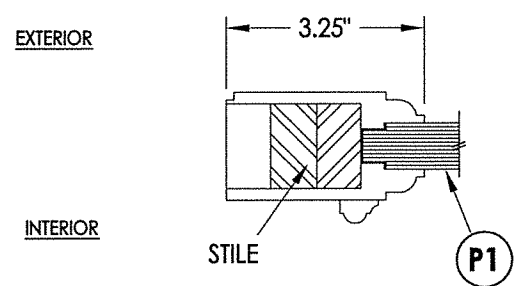

2
3 HORIZONTAL CROSS SECTION

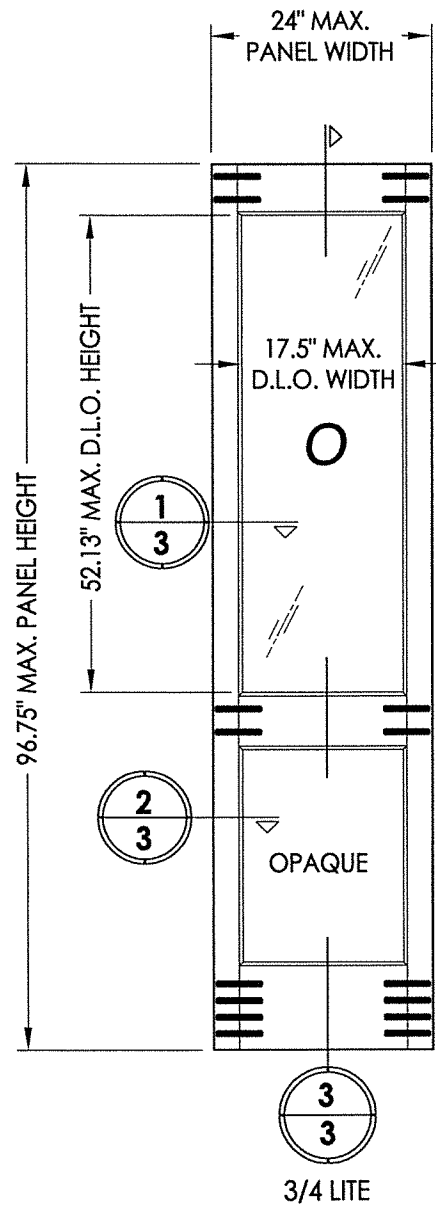

50 WOOD SIDELITE PANEL
3/4 LITE

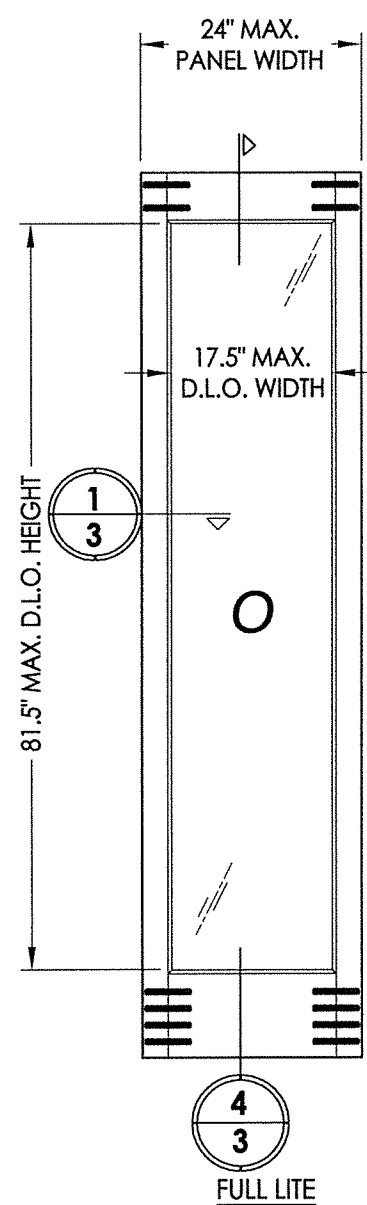

4
3 FULL LITE

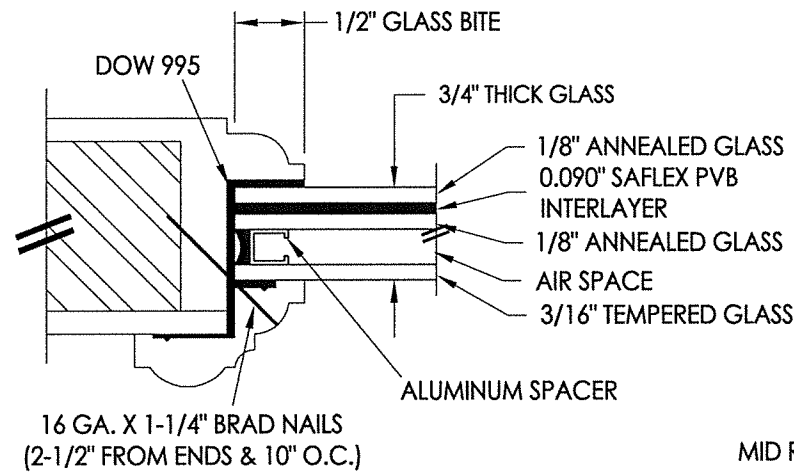

G1 GLAZING DETAIL

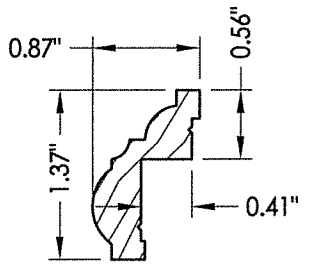

GLAZING BEAD

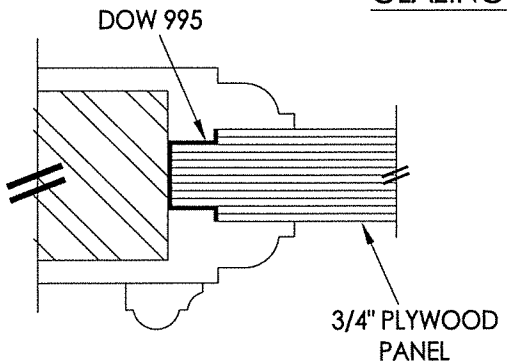

P1 PANEL INFIL DETAIL

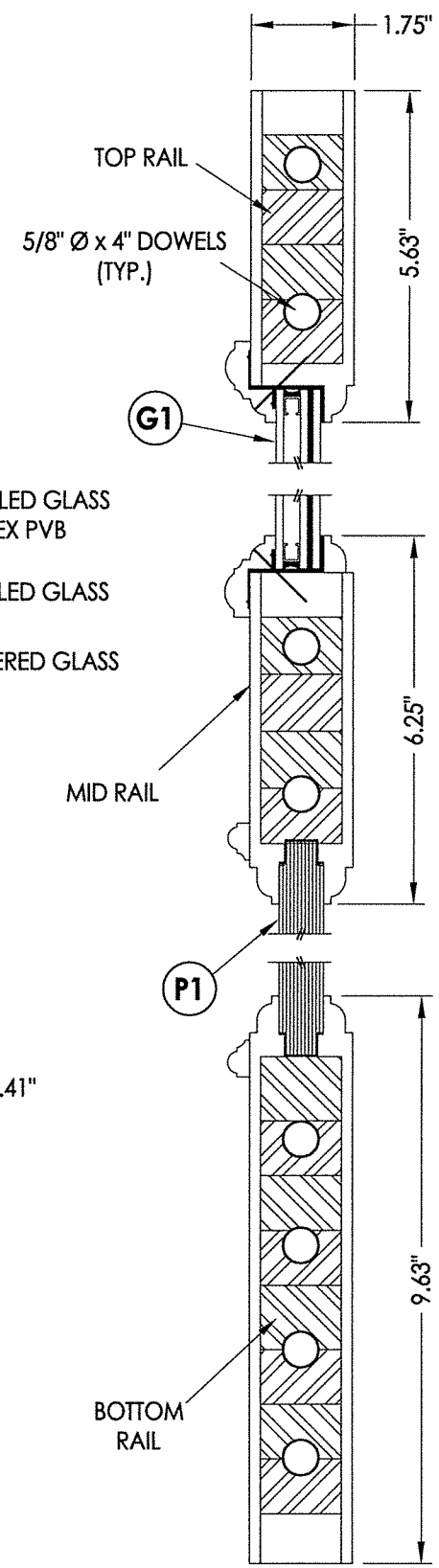

3
3 VERTICAL CROSS SECTION

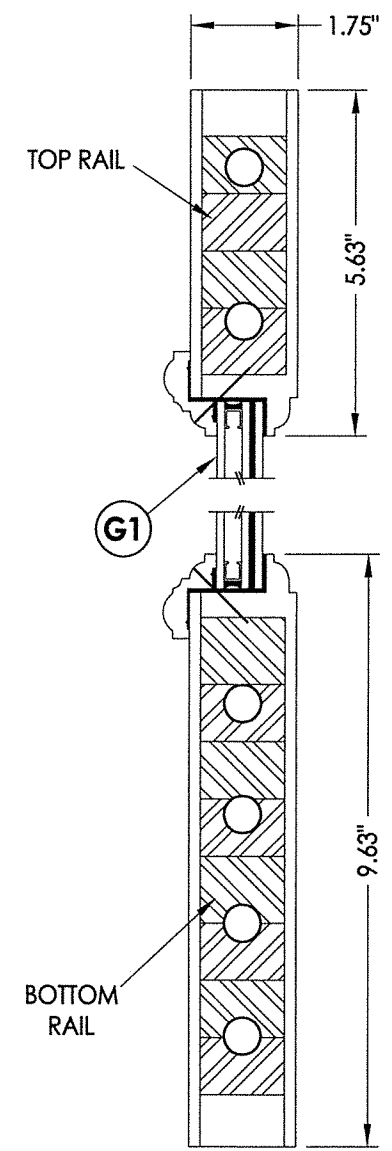

4
3 VERTICAL CROSS SECTION

FLORIDA PROFESSIONAL ENGINEER
F. SCHMIDT
 LICENSE No. 43409
 STATE OF FLORIDA
 PROFESSIONAL ENGINEER

October 12, 2017
 Documents Prepared By:
 Lyndon F. Schmidt
 P.E. No. 43409

RW BUILDING CONSULTANTS, INC.
 P.O. Box 230, Vairico, FL 33595
 Phone No.: 813.659.9197
 FBPE C.A. No. 9813

PRODUCT:	SOUTHEASTERN SASH & DOOR WOOD DOOR		
PART OR ASSEMBLY:	SIDELITE PANEL DETAILS		
DATE:	5/10/17		
SCALE:	N.T.S.		
DWG. BY:	JK		
CHK. BY:	LFS		
DRAWING NO.:	FL-22347.3		
SHEET	3 OF 14		
NO.	DATE	BY	REVISIONS
1	10/12/17	UPDATE TO 6TH ED. (2017)	FBC
			LFS

© 2017 R.W. BUILDING CONSULTANTS INC.

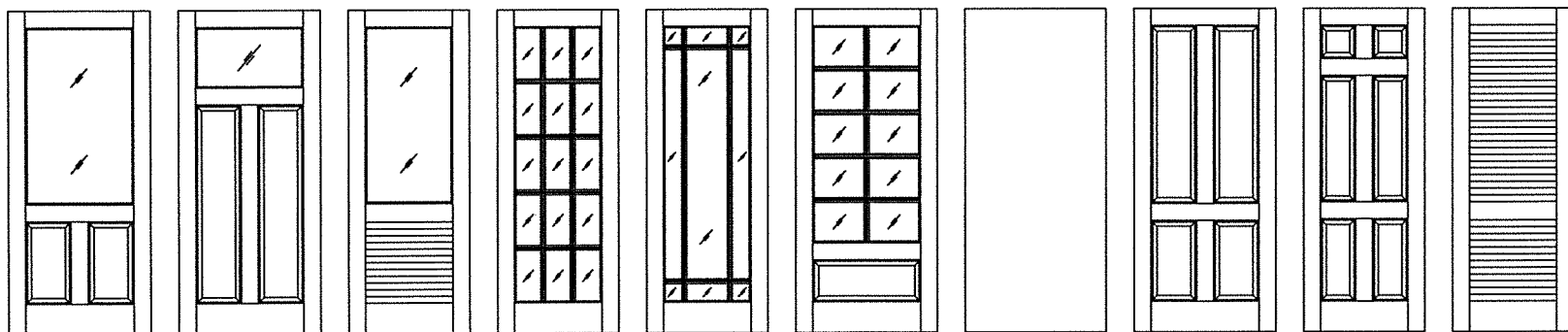
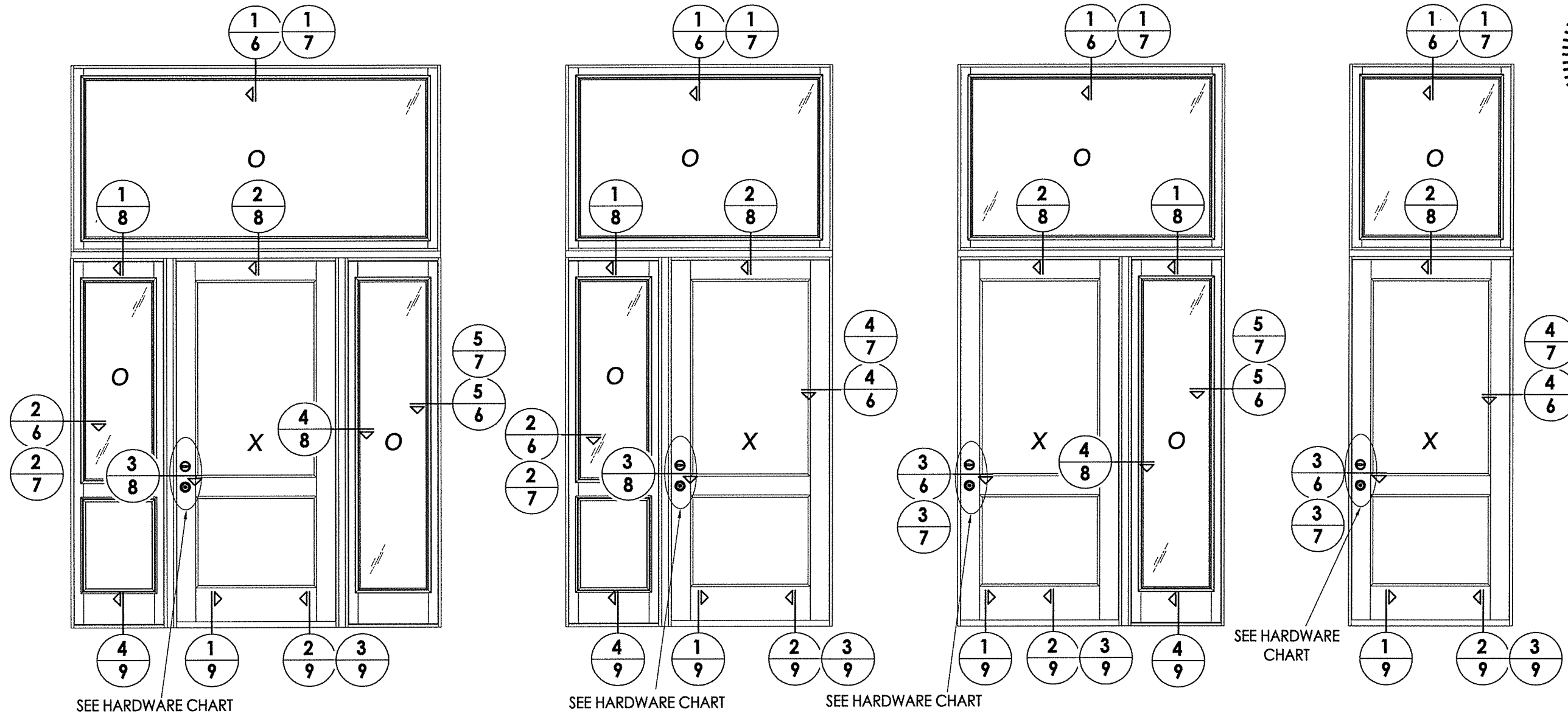

SOUTHEASTERN SASH & DOOR Door Panel Options
 Panel options shown are for illustration and are representative only.
 Surface applied muntins are used for simulated divided lites shown.

HARDWARE TABLE	
MANUFACTURER	MODEL
EMTEK	Mortise: 3545 Entry Set
SCHLAGE	KNOB: F51 DEADBOLT: B60N
KWIKSET	KNOB: SIGNATURE SERIES DEADBOLT: SIGNATURE SERIES (980)

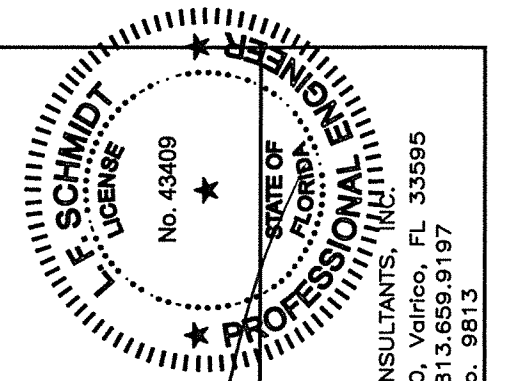

October 12, 2017
 Documents Prepared By:
 Lyndon F. Schmidt
 P.E. No. 43409
 RW BUILDING CONSULTANTS, INC.
 P.O. Box 230, Valrico, FL 33595
 Phone No.: 813.659.9197
 FBPE C.A. No. 9813

PRODUCT:
 SOUTHEASTERN SASH & DOOR
 WOOD DOOR

PART OR ASSEMBLY:
 ELEVATIONS

NO.	DATE	REVISIONS
1	10/12/17	UPDATE TO 6TH ED. (2017) FBC
		LFS
		BY

DATE: 5/10/17
 SCALE: N.T.S.
 DWG. BY: JK
 CHK. BY: LFS
 DRAWING NO.: FL-22347.3
 SHEET 5 of 14

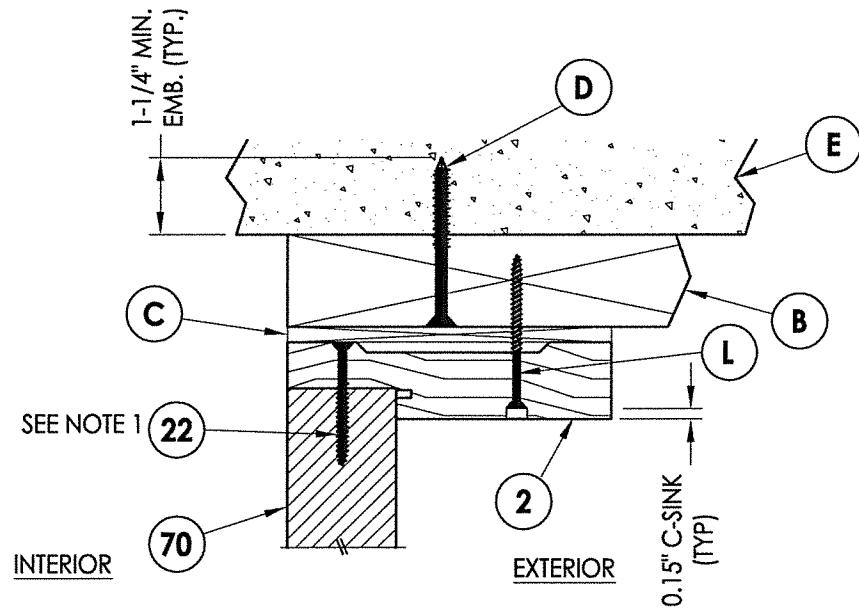

1 **VERTICAL CROSS SECTION**
6 Shown w/ 2X Buck
 Inswing shown (Outswing similar)

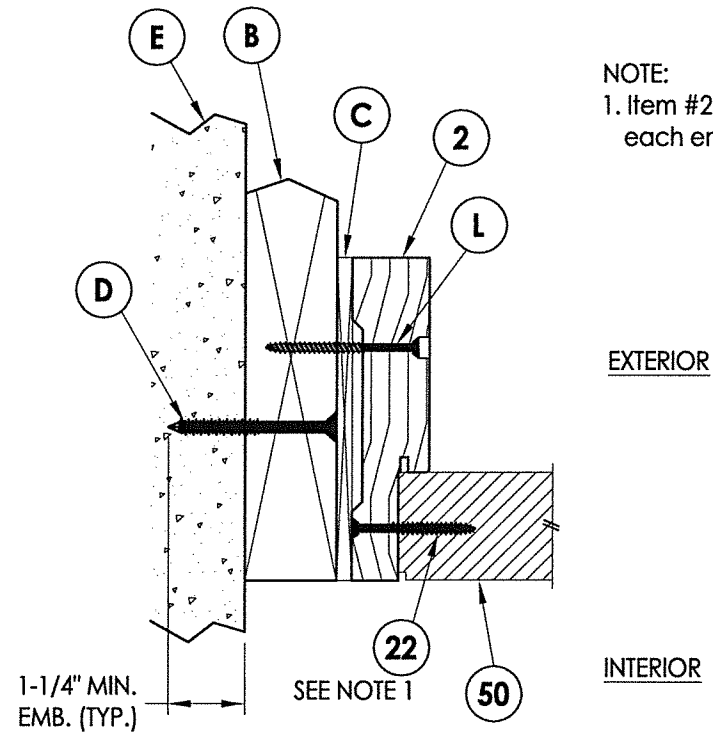

2 **HORIZONTAL CROSS SECTION**
6 Shown w/ 2X Buck
 Inswing shown (Outswing similar)

NOTE:
 1. Item #22 located 4" from each end then 7 more (9 total).

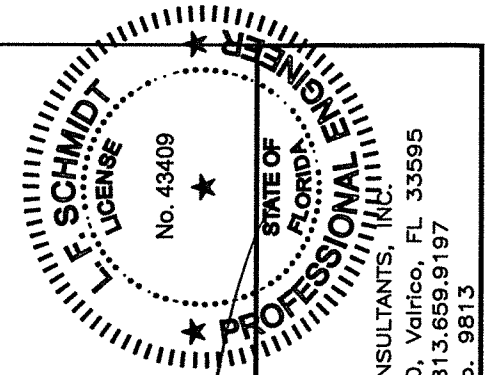

October 12, 2017
 Documents Prepared By:
 Lyndon F. Schmidt
 P.E. No. 43409
 RFW BUILDING CONSULTANTS, INC.
 P.O. Box 230, Valrico, FL 33595
 Phone No.: 813.659.9197
 FBPE C.A. No. 9813

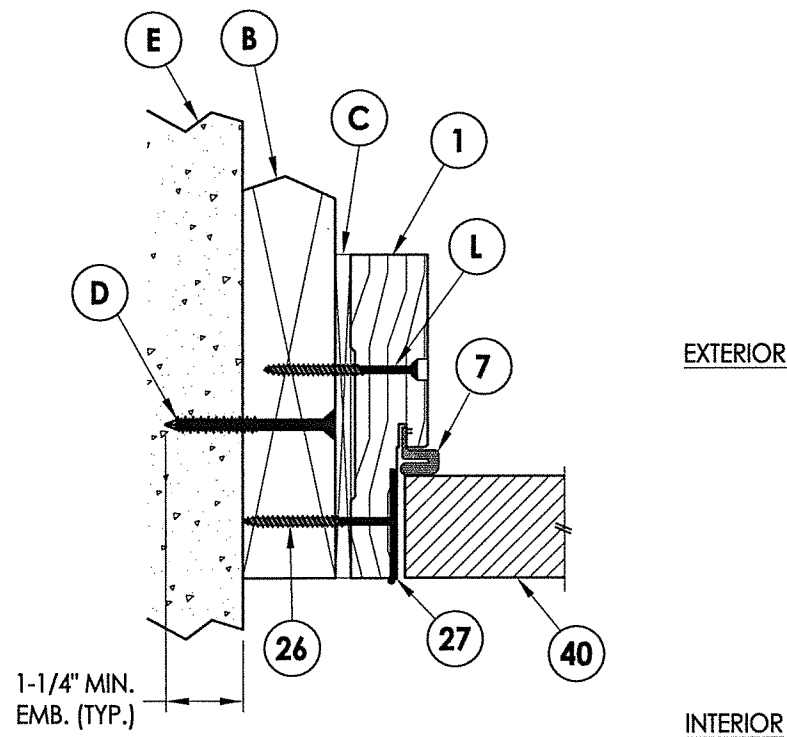

3 **HORIZONTAL CROSS SECTION**
6 Shown w/ 2X Buck
 Inswing shown (Outswing similar)

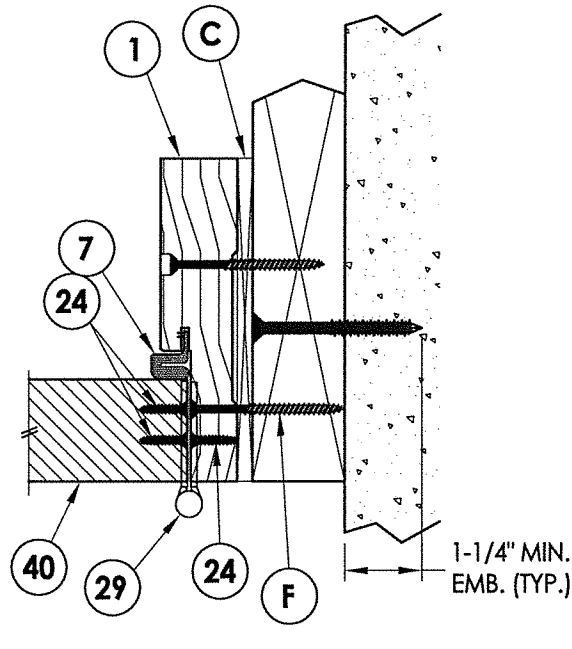

4 **HORIZONTAL CROSS SECTION**
6 Shown w/ 2X Buck
 Inswing shown (Outswing similar)

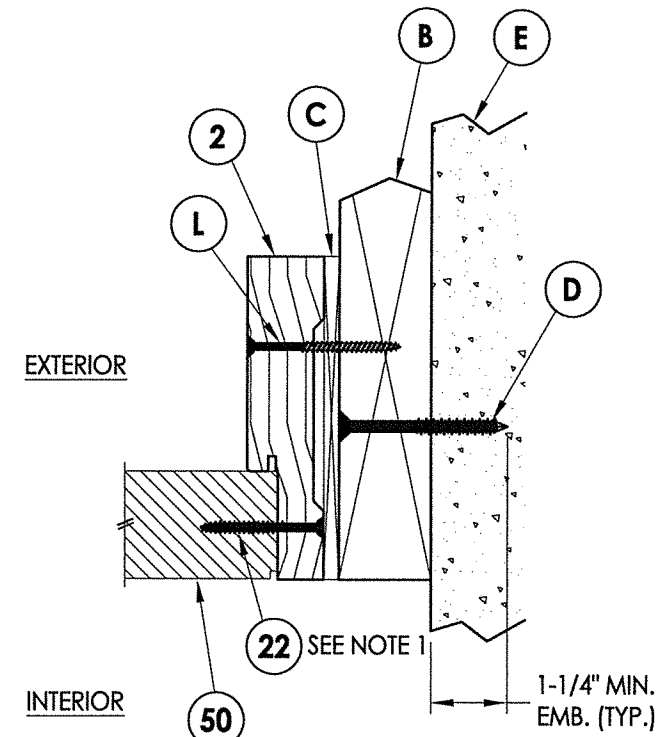

5 **HORIZONTAL CROSS SECTION**
6 Shown w/ 2X Buck
 Inswing shown (Outswing similar)

PRODUCT:		SOUTHEASTERN SASH & DOOR WOOD DOOR	
PART OR ASSEMBLY:		HORIZONTAL & VERTICAL CROSS SECTIONS (2X BUCK)	
NO.	DATE	BY	REVISIONS
1	10/12/17	LFS	UPDATE TO 6TH ED. (2017) FBC
DATE: 5/10/17		SCALE: N.T.S.	
DWG. BY: JK		CHK. BY: LFS	
DRAWING NO.: FL-22347.3		SHEET 6 OF 14	

R:\Clients\Southeastern Sash & Door\A - Florida Product Approvals\FL-22347C - Drawings\FL-22347.1-3.dwg, 7.3

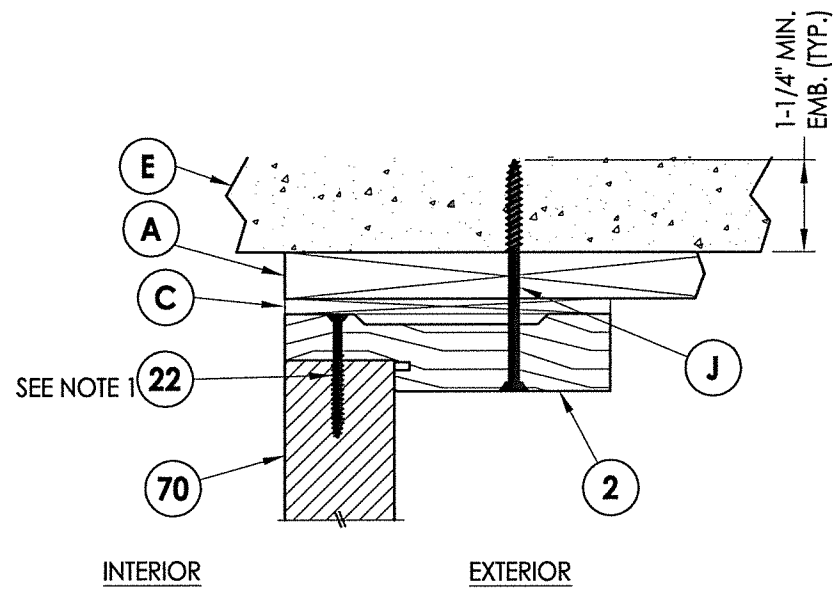

1 VERTICAL CROSS SECTION
7 Shown w/ 1X Buck
 Inswing shown (Outswing similar)

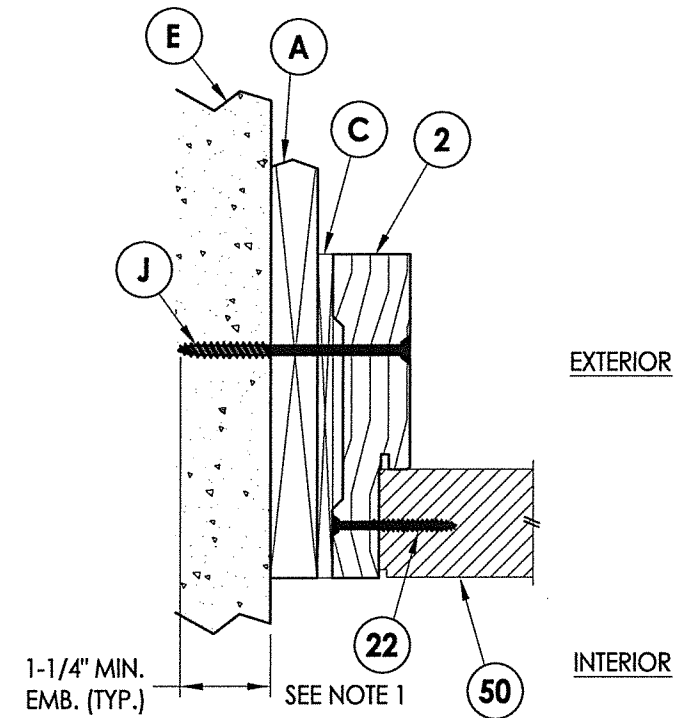

2 HORIZONTAL CROSS SECTION
7 Shown w/ 1X Buck
 Inswing shown (Outswing similar)

NOTE:
 1. Item #22 located 4" from each end then 7 more (9 total).
 2. Item #22 located 6" from each end (2 total).

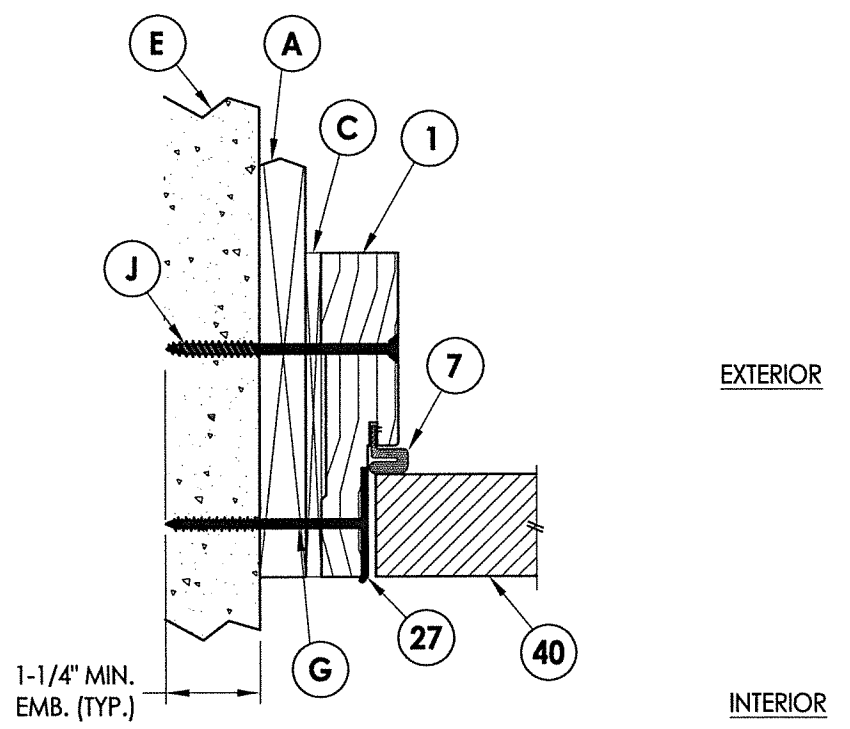

3 HORIZONTAL CROSS SECTION
7 Shown w/ 1X Buck
 Inswing shown (Outswing similar)

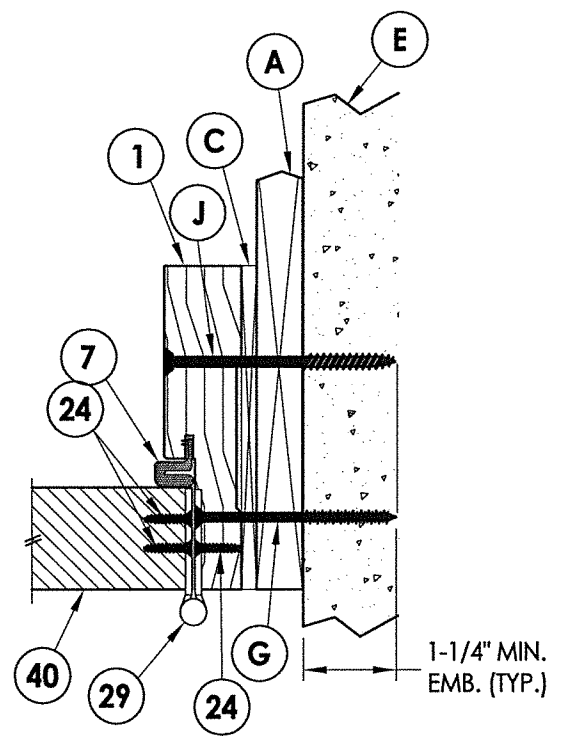

4 HORIZONTAL CROSS SECTION
7 Shown w/ 1X Buck
 Inswing shown (Outswing similar)

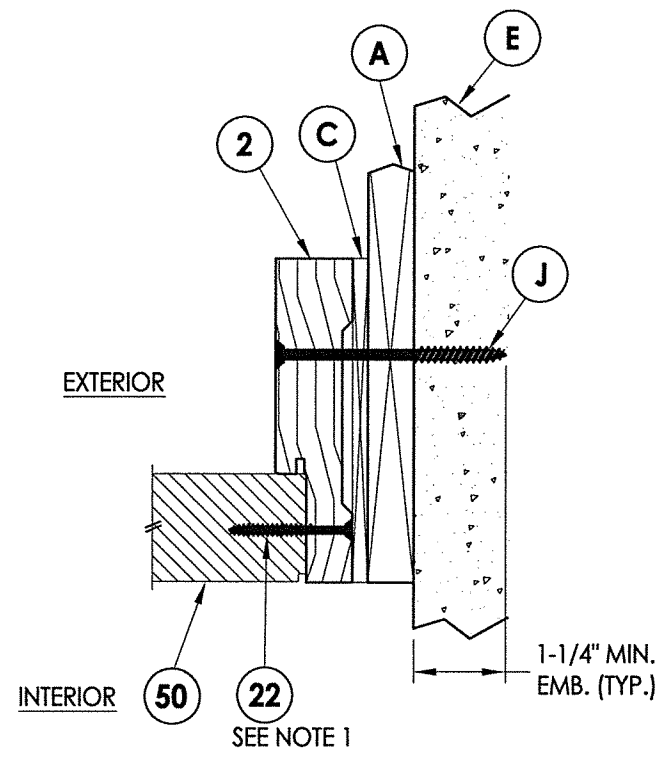

5 HORIZONTAL CROSS SECTION
7 Shown w/ 1X Buck
 Inswing shown (Outswing similar)

L. F. SCHMIDT
 LICENSE
 No. 43409
 STATE OF FLORIDA
 PROFESSIONAL ENGINEER

October 12, 2017
 Documents Prepared By:
 Lyndon F. Schmidt
 P.E. No. 43409

RW BUILDING CONSULTANTS, INC.
 P.O. Box 230, Valrico, FL 33595
 Phone No.: 813.659.9197
 FBPE C.A. No. 9813

PRODUCT:		SOUTHEASTERN SASH & DOOR WOOD DOOR	
PART OR ASSEMBLY:		HORIZONTAL & VERTICAL CROSS SECTIONS (1X BUCK)	
NO.	DATE	BY	REVISIONS
1	10/12/17	FBC	UPDATE TO 6TH ED. (2017)
		LFS	
DATE: 5/10/17			
SCALE: N.T.S.			
DWG. BY: JK			
CHK. BY: LFS			
DRAWING NO.: FL-22347.3			
SHEET 7 OF 14			

NOTE:
1. Item #22 located 6" from each end (2 total).

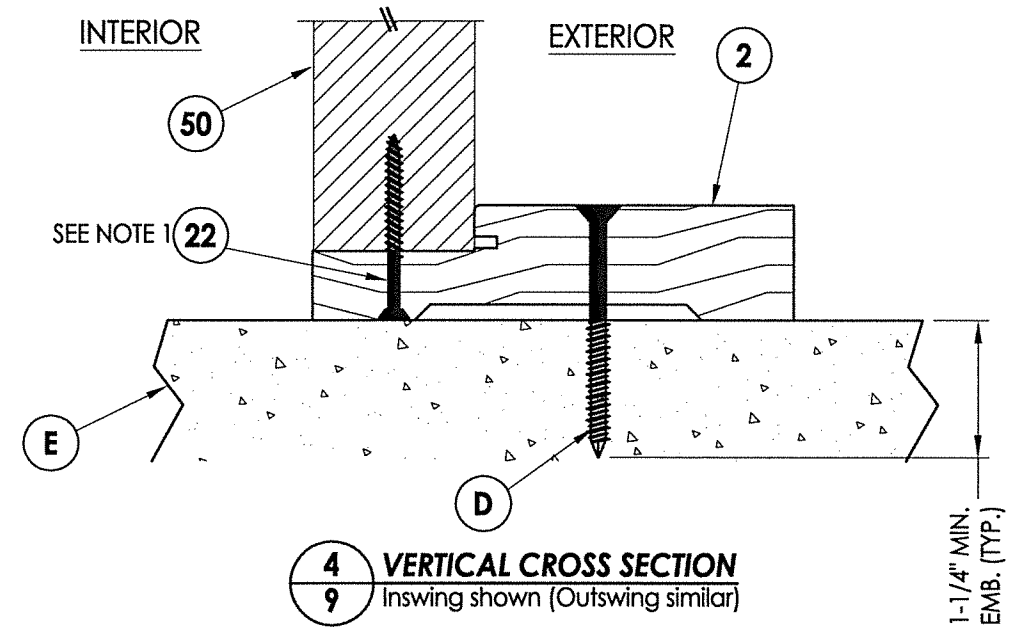
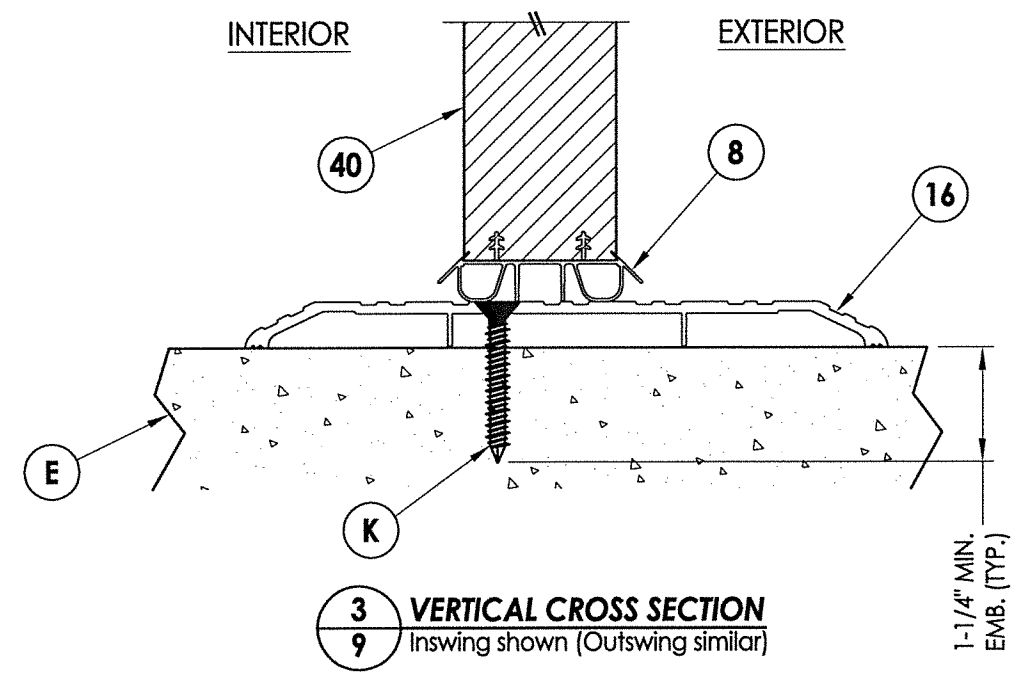
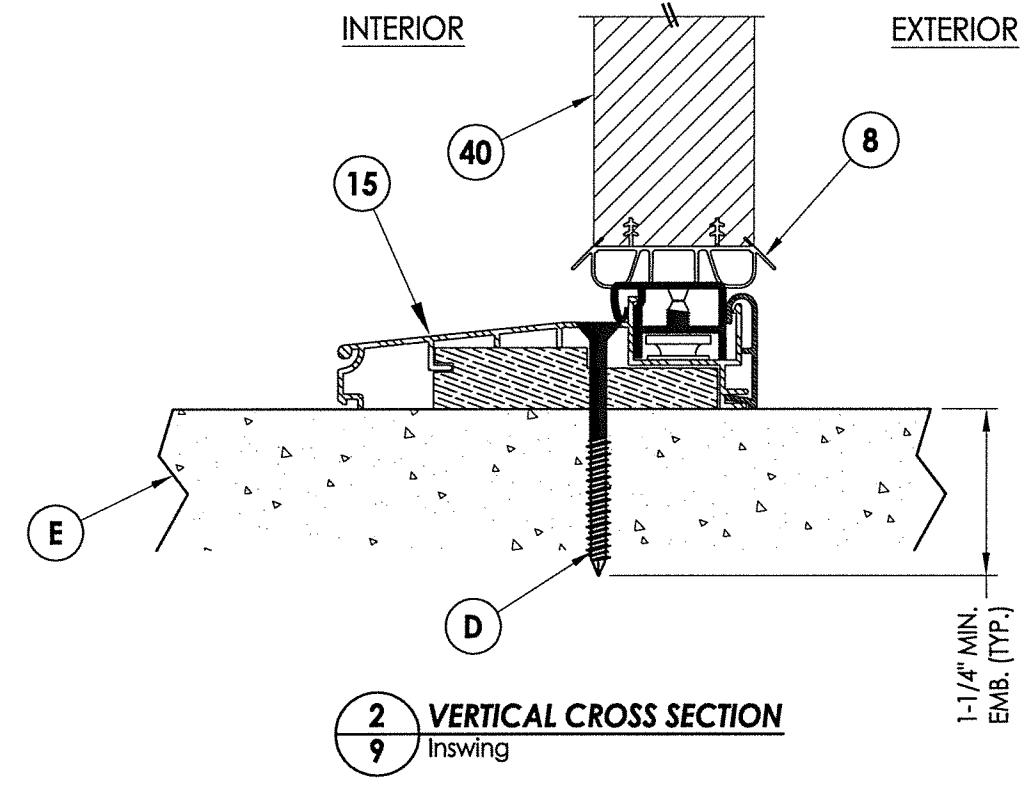
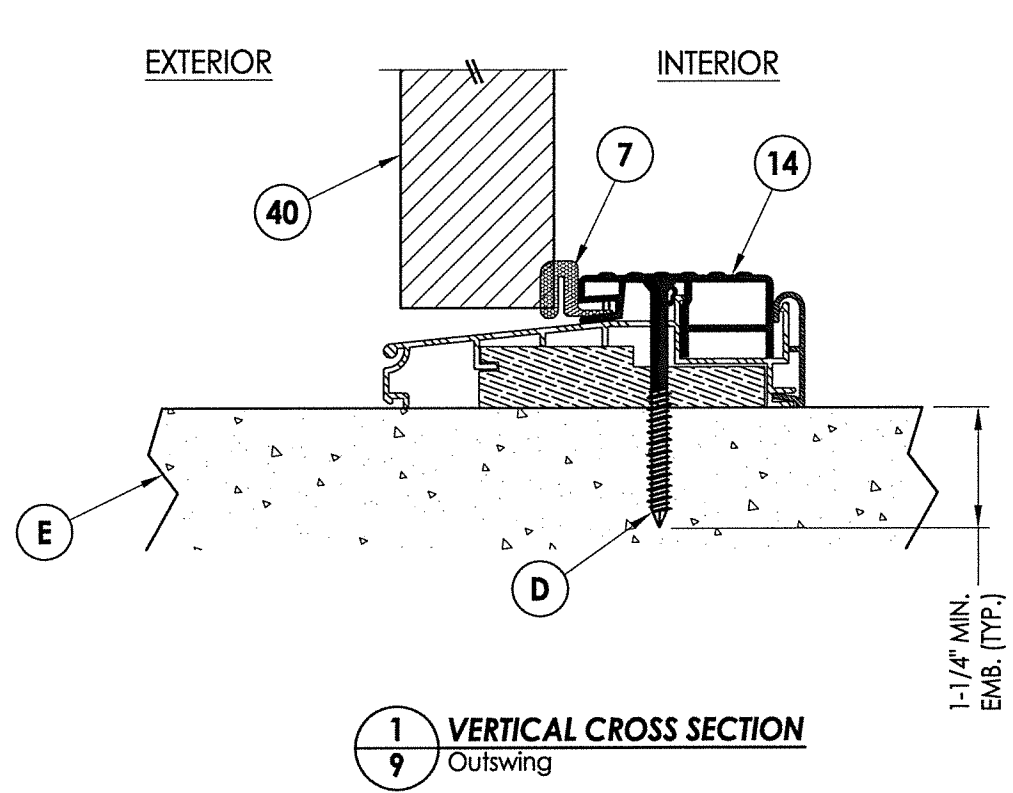

October 12, 2017
 Documents Prepared By:
 Lyndon F. Schmidt
 P.E. No. 43409

STATE OF FLORIDA
REGISTERED PROFESSIONAL ENGINEER
 L. F. SCHMIDT
 LICENSE No. 43409

R.W. BUILDING CONSULTANTS, INC.
 P.O. Box 230, Valrico, FL 33595
 Phone No.: 813.659.9197
 FBPE C.A. No. 9813

PRODUCT:	SOUTHEASTERN SASH & DOOR WOOD DOOR	
PART OR ASSEMBLY:	VERTICAL CROSS SECTIONS (THRESHOLD)	
DATE:	5/10/17	
SCALE:	N.T.S.	
DWG. BY:	JK	
CHK. BY:	LFS	
DRAWING NO.:	FL-22347.3	
SHEET	9 OF 14	
NO.	DATE	REVISIONS
1	10/12/17	UPDATE TO 6TH ED. (2017) FBC
		LFS
		BY

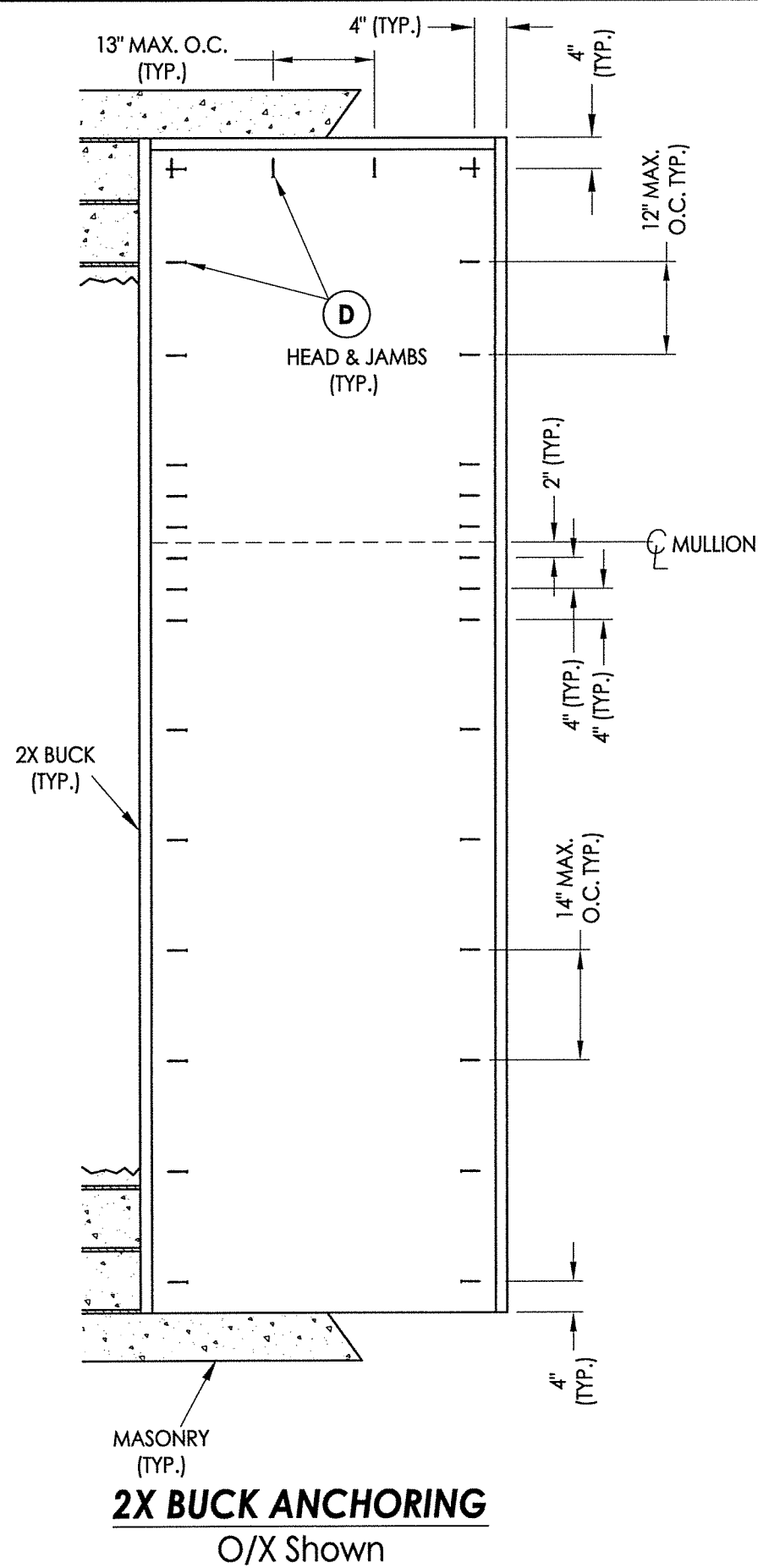

2X BUCK ANCHORING
O/X Shown

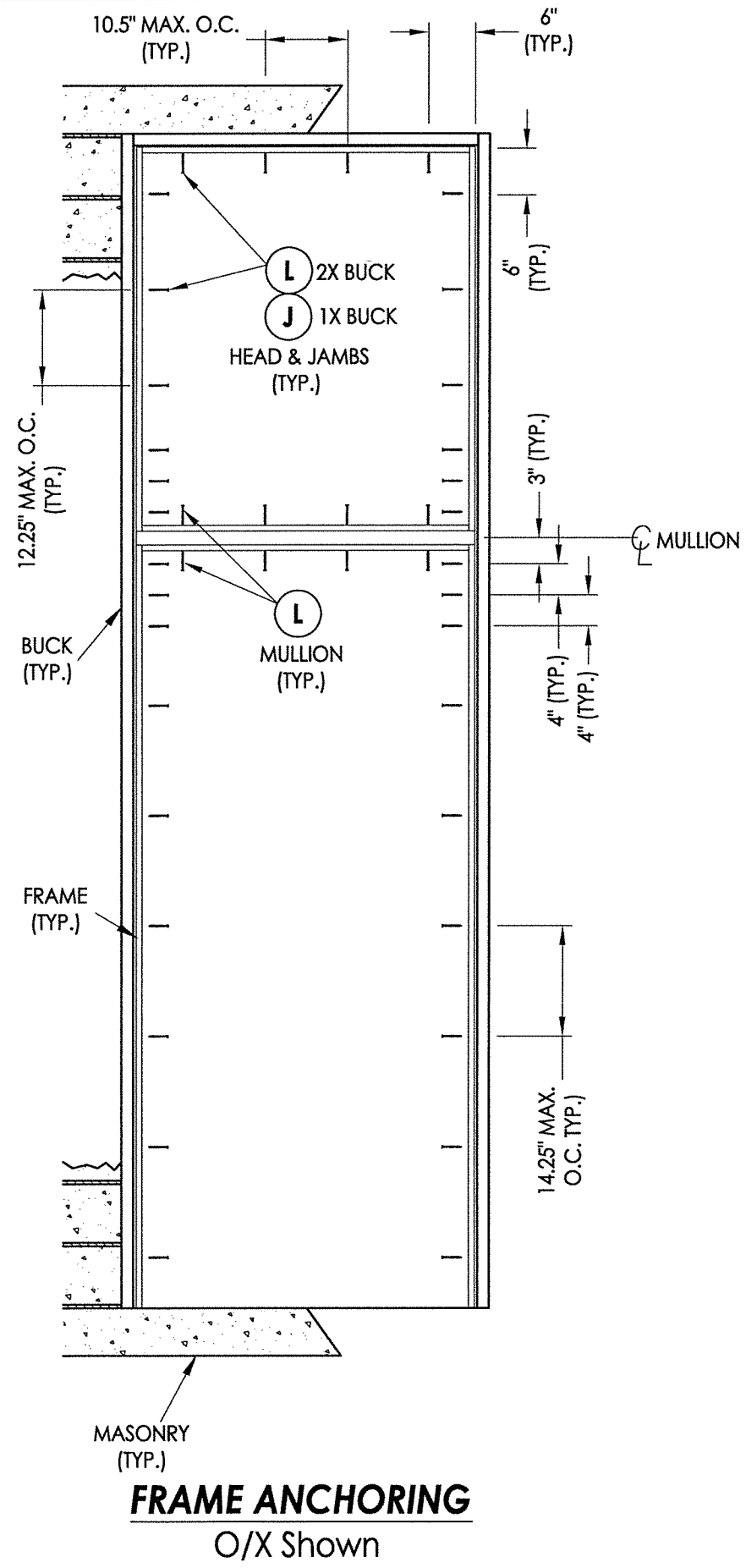

FRAME ANCHORING
O/X Shown

NOTE:
1. ALL FRAME CORNERS SECURED WITH (3) #8 X 2-1/2" FH DEEP THREAD WOOD SCREWS @ SILL.

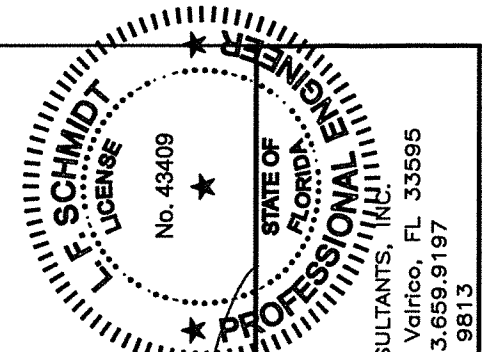

October 12, 2017
 Documents Prepared By:
 Lyndon F. Schmidt
 P.E. No. 43409
R.W. BUILDING CONSULTANTS, INC.
 P.O. Box 230, Valrico, FL 33595
 Phone No.: 813.659.9197
 FBPE C.A. No. 9813

PRODUCT:
 SOUTHEASTERN SASH & DOOR
 WOOD DOOR
 PART OR ASSEMBLY:
 BUCK & FRAME ANCHORING
 (O/X)

NO.	DATE	REVISIONS
1	10/12/17	UPDATE TO 6TH ED. (2017) FBC
		LFS
		BY

DATE: 5/10/17
 SCALE: N.T.S.
 DWG. BY: JK
 CHK. BY: LFS
 DRAWING NO.: FL-22347.3
 SHEET 10 OF 14

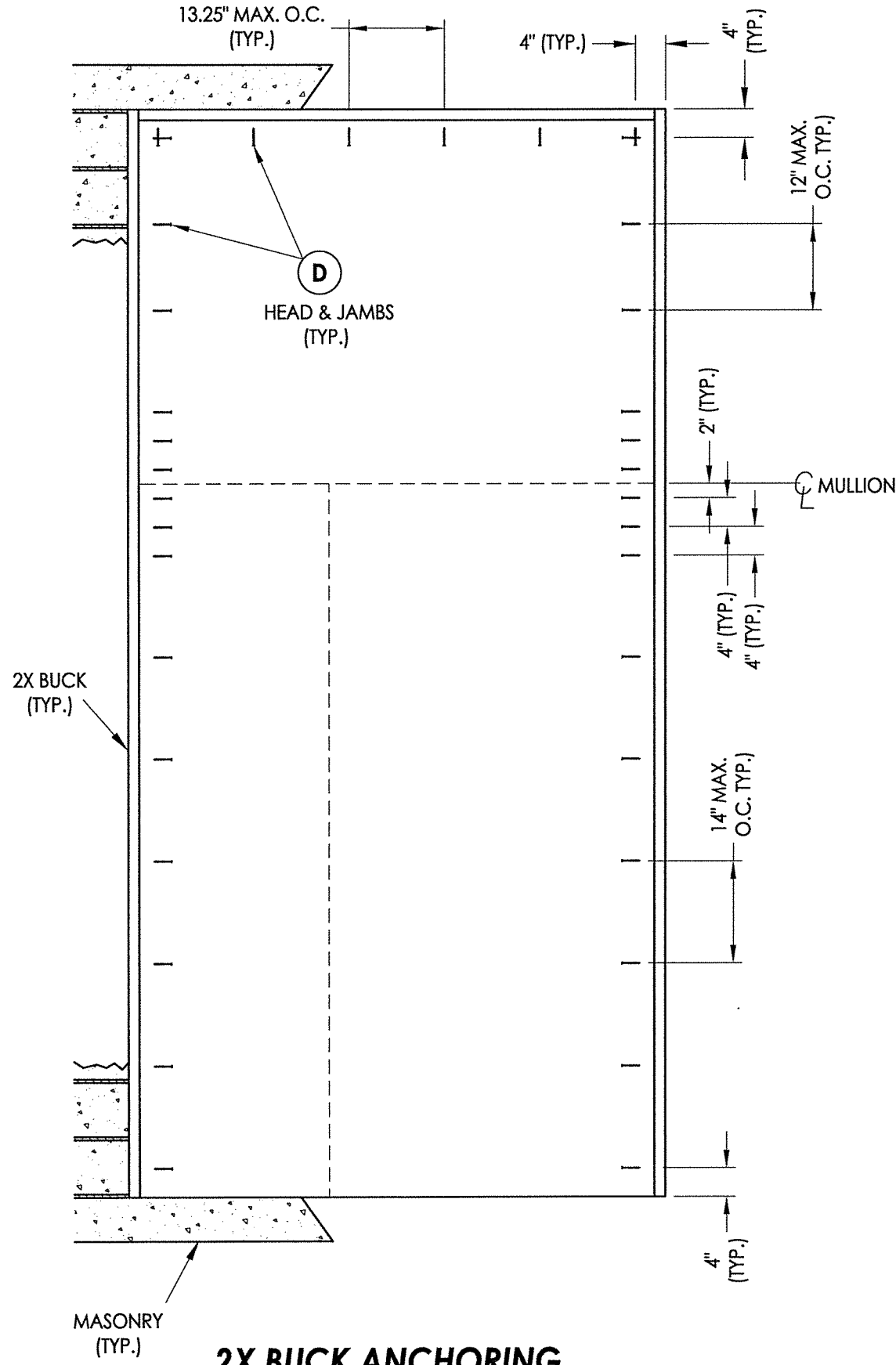

2X BUCK ANCHORING
O/OX Shown (O/XO - Similar)

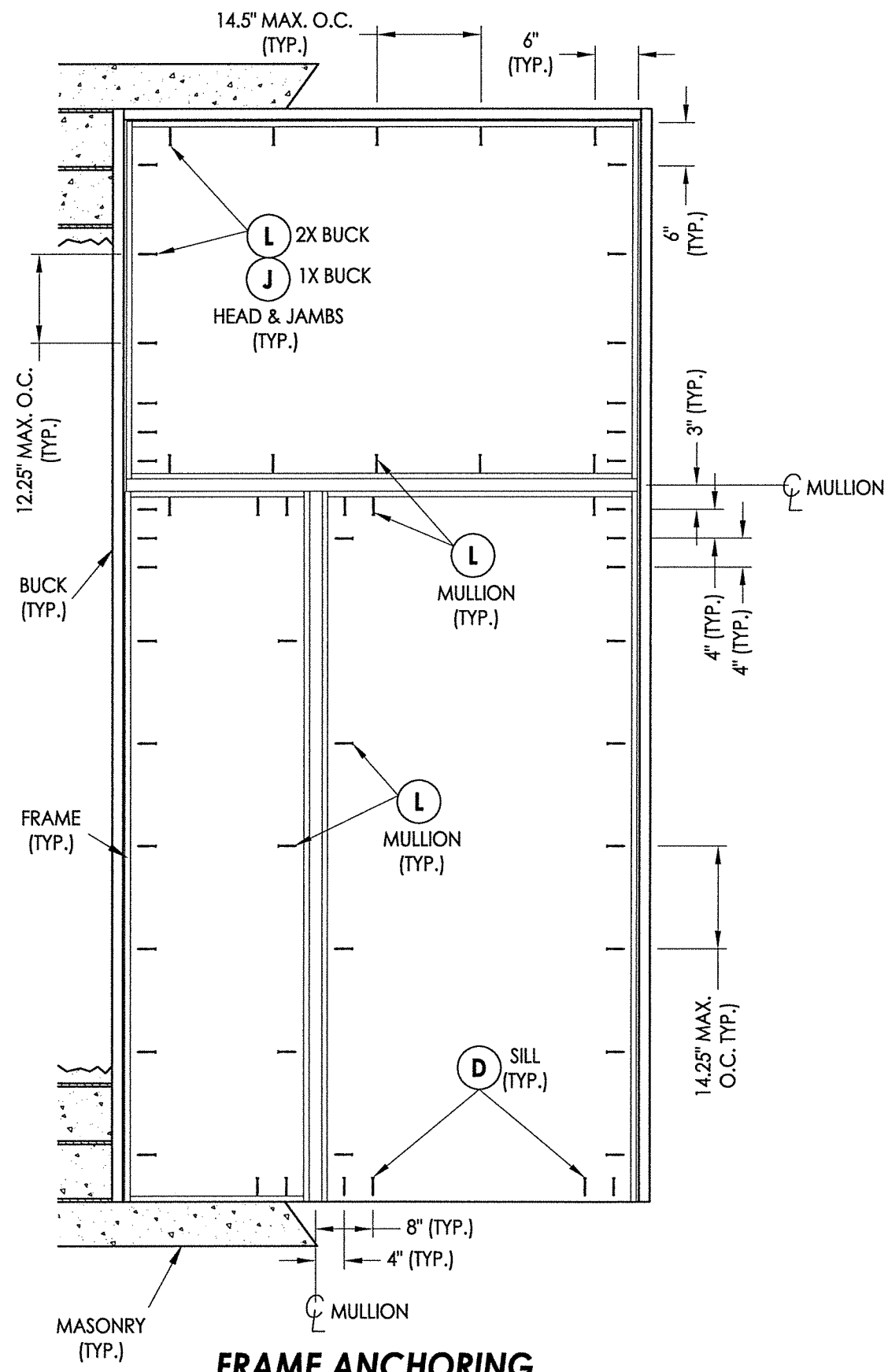

FRAME ANCHORING
O/OX Shown (O/XO - Similar)

NOTE:
1. ALL FRAME CORNERS SECURED WITH (3) #8 X 2-1/2" FH DEEP THREAD WOOD SCREWS @ SILL.

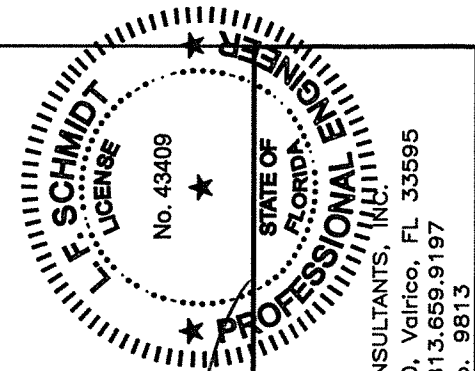

October 12, 2017
 Documents Prepared By:
 Lyndon F. Schmidt
 P.E. No. 43409
 R.W. BUILDING CONSULTANTS, INC.
 P.O. Box 230, Vairico, FL 33595
 Phone No.: 813.659.9197
 FBPE C.A. No. 9813

PRODUCT:
 SOUTHEASTERN SASH & DOOR
 WOOD DOOR
 PART OR ASSEMBLY:
 BUCK & FRAME ANCHORING
 (O/OX)

NO.	DATE	DESCRIPTION	BY
1	10/12/17	UPDATE TO 6TH ED. (2017)	LFS

DATE: 5/10/17
 SCALE: N.T.S.
 DWG. BY: JK
 CHK. BY: LFS
 DRAWING NO.: FL-22347.3
 SHEET 11 OF 14

R:\Clients\Southeastern Sash & Door\A - Florida Product Approvals\FL-22347C - Drawings\FL-22347C - 1-3.dwg, 12.3

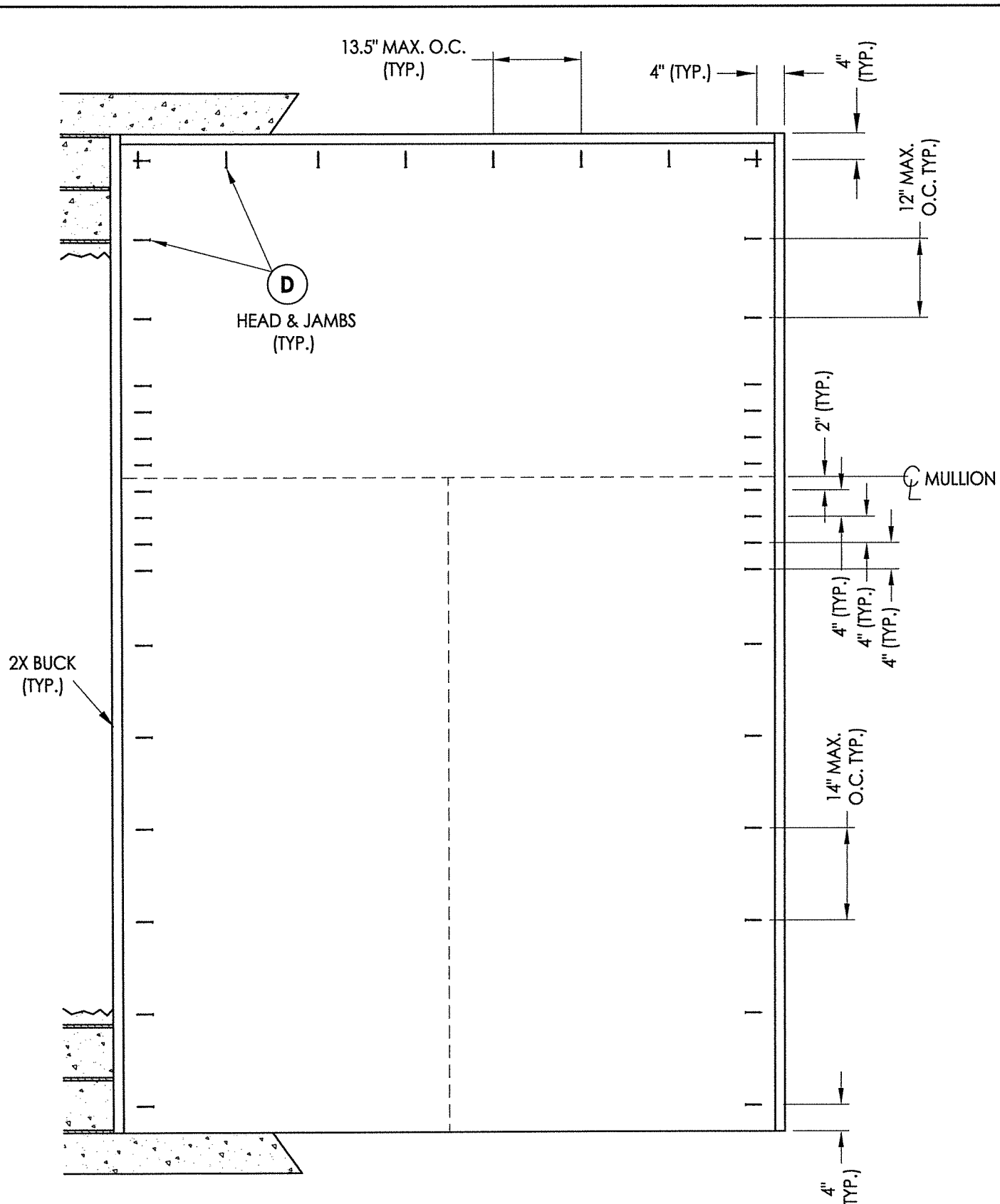

2X BUCK ANCHORING
O/OXO

NOTE:
1. ALL FRAME CORNERS SECURED WITH (3) #8 X 2-1/2" FH DEEP THREAD WOOD SCREWS @ SILL.

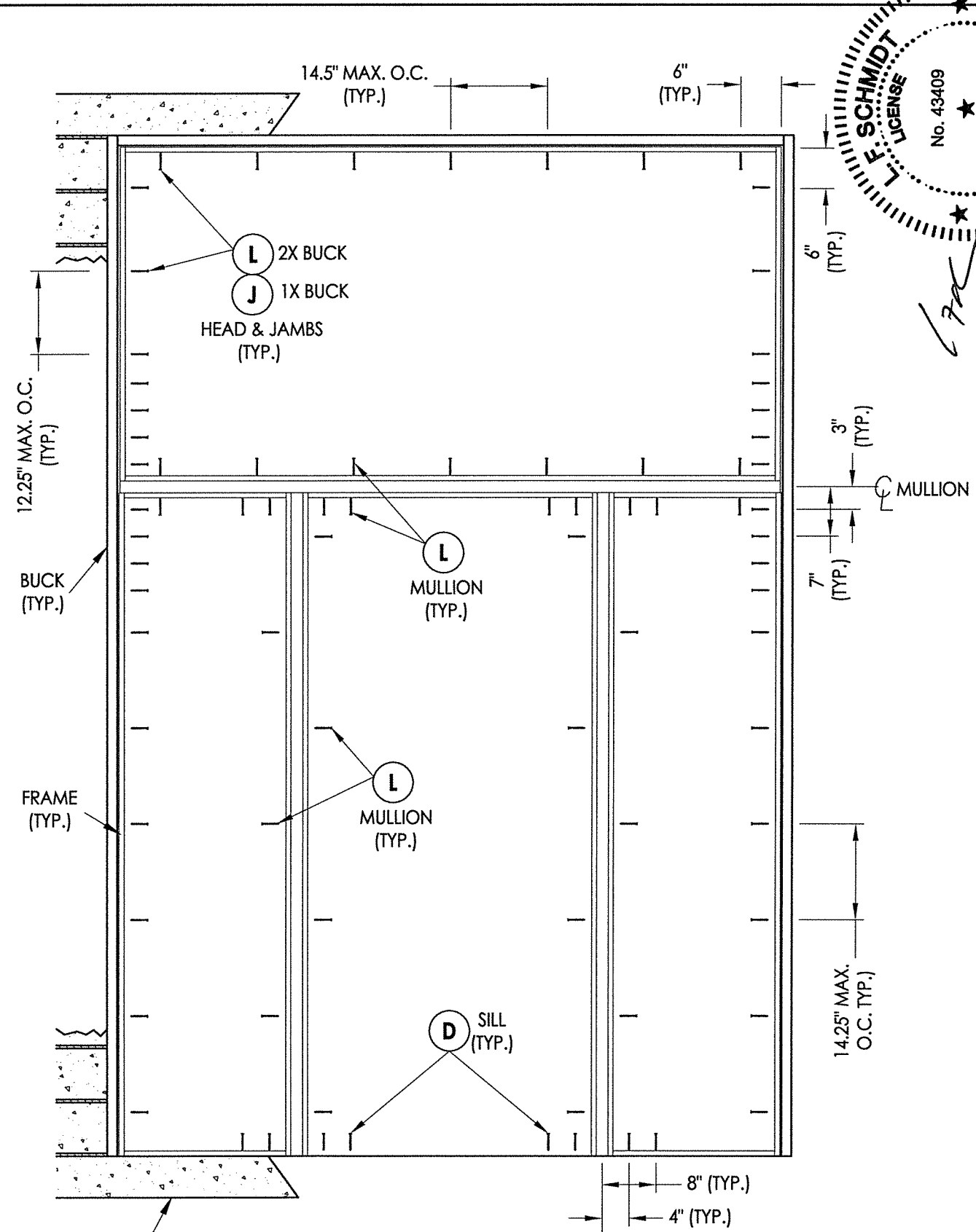

FRAME ANCHORING
O/OXO

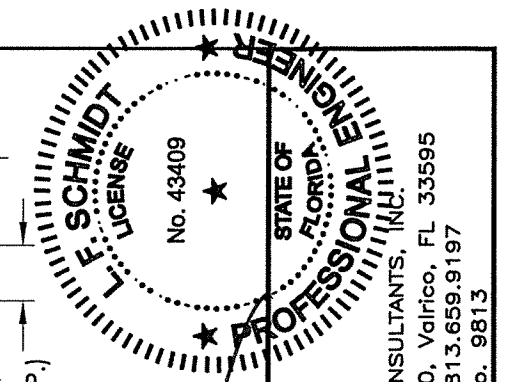

October 12, 2017
 Documents Prepared By:
 Lyndon F. Schmidt
 P.E. No. 43409
 BUILDING CONSULTANTS, INC.
 P.O. Box 230, Valrico, FL 33595
 Phone No.: 813.659.9197
 FBPE C.A. No. 9813

PRODUCT:
 SOUTHEASTERN SASH & DOOR
 WOOD DOOR
 PART OR ASSEMBLY:
 BUCK & FRAME ANCHORING
 (O/OXO)

NO.	DATE	DESCRIPTION	BY
1	10/12/17	UPDATE TO 6TH ED. (2017) FBC	LFS

DATE: 5/10/17
 SCALE: N.T.S.
 DWG. BY: JK
 CHK. BY: LFS
 DRAWING NO.: FL-22347.3
 SHEET 12 OF 14

© 2017 R.W. BUILDING CONSULTANTS INC.

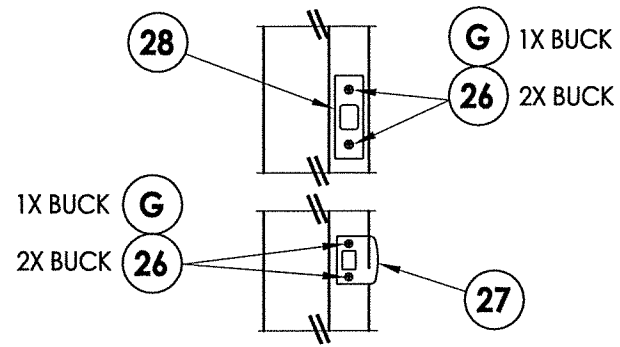

LATCH & DEADBOLT STRIKE DETAIL
SCHLAGE

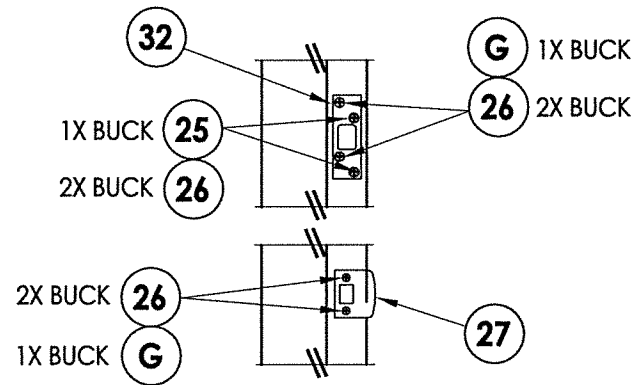

LATCH & DEADBOLT STRIKE DETAIL
KWIKSET

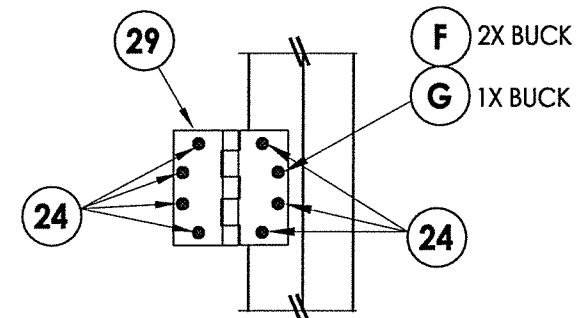

HINGE DETAIL

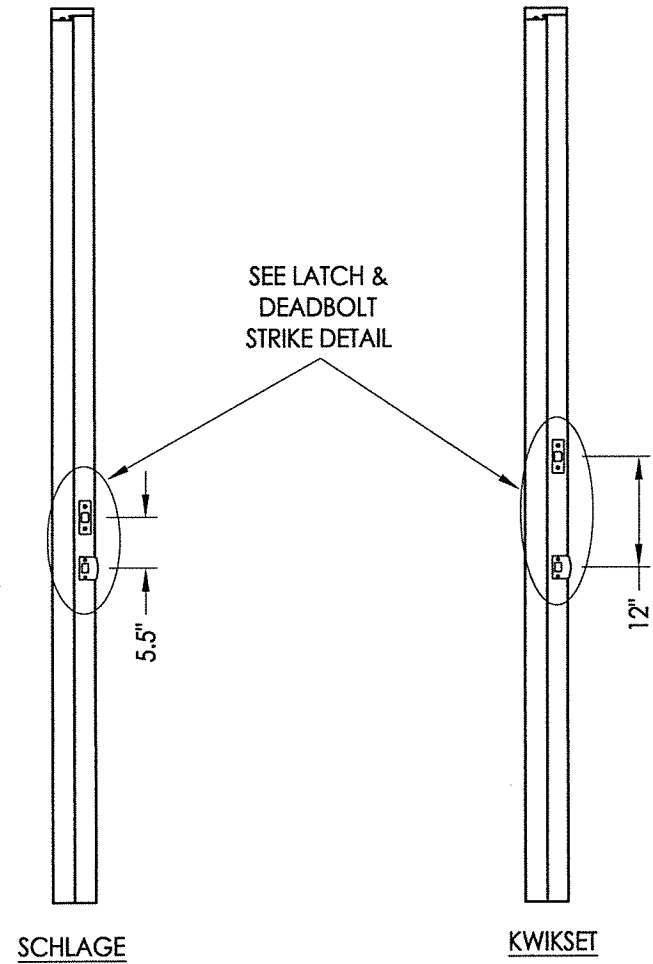

LATCH & DEADBOLT DETAILS

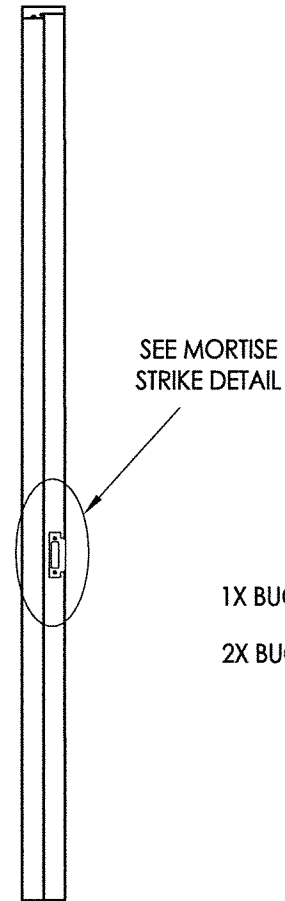

MORTISE LOCK DETAILS

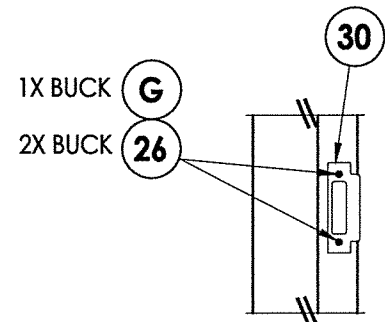

MORTISE STRIKE DETAIL

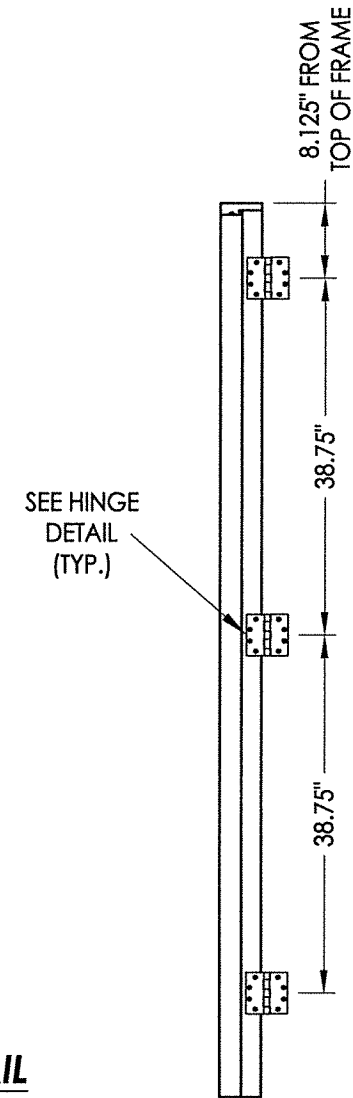

HINGE JAMB

October 12, 2017
 Documents Prepared By:
 Lyndon F. Schmidt
 P.E. No. 43409

R.W. BUILDING CONSULTANTS, INC.
 P.O. Box 230, Valrico, FL 33595
 Phone No.: 813.659.9197
 FBPE C.A. No. 9813

PRODUCT: SOUTHEASTERN SASH & DOOR WOOD DOOR
 PART OR ASSEMBLY: HARDWARE DETAILS

NO.	DATE	BY	REVISIONS
1	10/12/17	FBC	UPDATE TO 6TH ED. (2017)
		LFS	

DATE: 5/10/17
 SCALE: N.T.S.
 DWG. BY: JK
 CHK. BY: LFS
 DRAWING NO.: FL-22347.3
 SHEET 13 OF 14

BILL OF MATERIALS		
ITEM #	DESCRIPTION	MATERIAL
A	1X BUCK (SG >= 0.42)	WOOD
B	2X BUCK (SG >= 0.42)	WOOD
C	1/4" MAX. SHIM SPACE	-
D	1/4" X 2-3/4" PFH ELCO OR ITW CONCRETE SCREW	STEEL
E	MASONRY - 3,000 PSI MIN. CONCRETE CONFORMING TO ACI 301 OR HOLLOW BLOCK CONFORMING TO ASTM C90	CONCRETE
F	#12 X 2-1/2" PFH WOOD SCREW	STEEL
G	3/16" X 3-1/4" PFH ITW CONCRETE SCREW	STEEL
J	1/4" X 3-3/4" PFH ELCO OR ITW CONCRETE SCREW	STEEL
L	#10 X 2-1/2" PFH WOOD SCREW (1.15" MIN. EMBEDMENT)	STEEL
K	1/4" X 1-3/4" PFH ELCO OR ITW CONCRETE SCREW	STEEL
1	JAMB (Door)	WOOD
2	JAMB (Transom and Sidelite)	WOOD
3	MULLION	LSL
7	WEATHERSTRIP	FOAM
8	SWEEP	VINYL
14	OUTSWING THRESHOLD	ALUM/COMP
15	INSWING THRESHOLD	ALUM/COMP
16	ADA THRESHOLD	ALUM
22	#10 X 2" PFH WOOD SCREW	STEEL
24	#12 X 1" PFH WOOD SCREW	STEEL
25	#8 X 1-3/4" PFH WOOD SCREW	STEEL
26	#8 X 2-1/2" PFH WOOD SCREW	STEEL
27	LATCH STRIKE PLATE	STEEL
28	DEADBOLT STRIKE PLATE	STEEL
29	4.5" X 4.5" HINGE	STEEL
30	MORTISE STRIKE PLATE	STEEL
32	DEADBOLT SECURITY STRIKE PLATE	STEEL
40	DOOR PANEL	-
50	SIDELITE PANEL	-
70	TRANSOM PANEL	-

WOOD FRAME COMPONENTS: SIPO (UTILE) (G = 0.53)

CONCRETE ANCHOR NOTES:

- Concrete anchor locations at the corners may be adjusted to maintain the min. edge distance to mortar joints.
- Concrete anchor locations noted as "MAX. ON CENTER" must be adjusted to maintain the min. edge distance to mortar joints, additional concrete anchors may be required to ensure the "MAX. ON CENTER" dimension are not exceeded.
- Concrete anchor table:

ANCHOR TYPE	ANCHOR SIZE	MIN. EMBEDMENT	MIN. CLEARANCE TO MASONRY EDGE	MIN. CLEARANCE TO ADJACENT ANCHOR
ITW TAPCON®	1/4"	1-1/4"	2"	4"
ELCO ULTRACON®	1/4"	1-1/4"	1"	4"
ITW TAPCON®	3/16"	1-1/4"	3"	1-1/2"

WOOD SCREW INSTALLATION NOTES:

- Maintain a minimum 5/8" edge distance, 1" end distance, & 1" o.c. spacing of wood screws to prevent the splitting of wood.

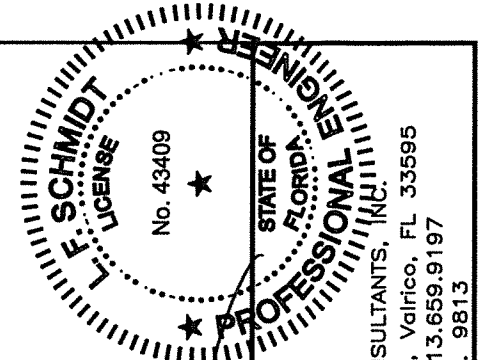
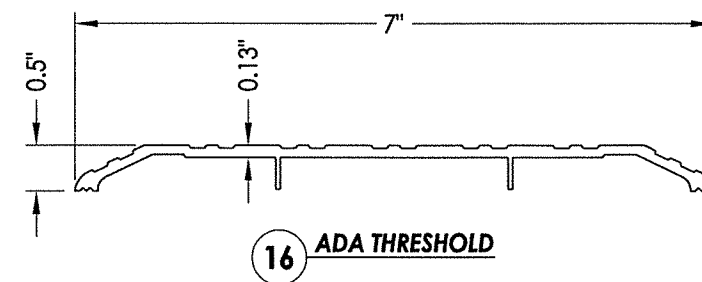
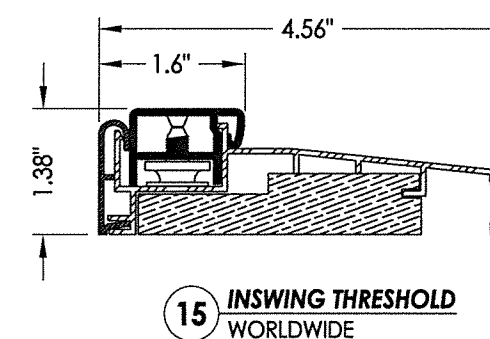
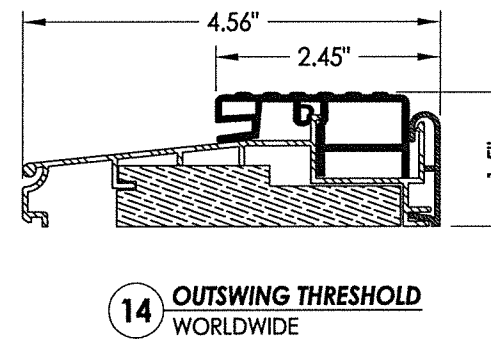
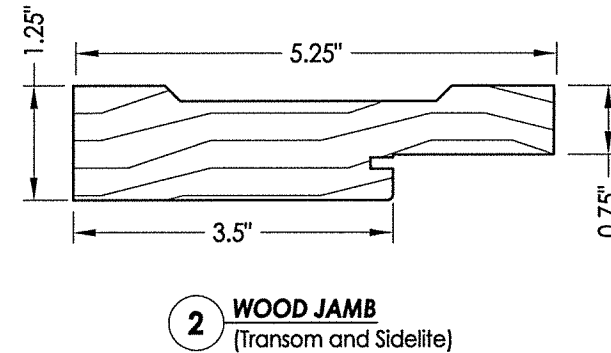
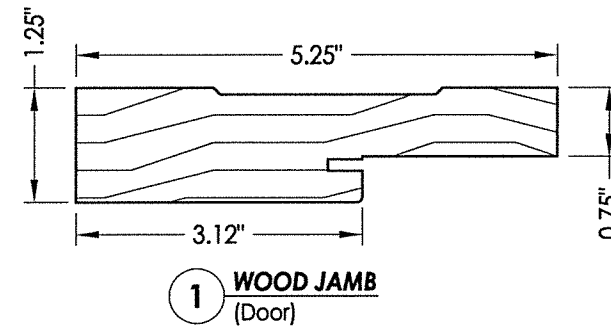

October 12, 2017
 Documents Prepared By:
 Lyndon F. Schmidt
 P.E. No. 43409
 R.W. BUILDING CONSULTANTS, INC.
 P.O. Box 230, Valrico, FL 33595
 Phone No.: 813.659.9197
 FBPE C.A. No. 9813

PRODUCT:	SOUTHEASTERN SASH & DOOR WOOD DOOR
PART OR ASSEMBLY:	BILL OF MATERIALS & COMPONENTS
DATE:	5/10/17
SCALE:	N.T.S.
DWG. BY:	JK
CHK. BY:	LFS
DRAWING NO.:	FL-22347.3
SHEET	14 OF 14